

# CITY OF Beachwood

REGULAR CITY COUNCIL MEETING MINUTES  
MONDAY, MARCH 9, 2026, 7:00 PM  
AT BEACHWOOD CITY HALL, COUNCIL CHAMBERS,  
25325 FAIRMOUNT BOULEVARD,  
BEACHWOOD, OHIO 44122

Called to order at 7:00 PM by Council President Danielle Shoykhet

-Pledge of Allegiance to the Flag of the United States of America-

1. Roll Call  
Present - Ms. DeLong, Mr. Isaacson, Ms. Jacobs, Ms. Shoykhet, Mr. Smith, Ms. Stern, Ms. Taylor  
Absent - None  
Others Present - Mayor Berns, Mr. Arrietta, Ms. Bieterman, Police Chief Grispino, Mr. Heiser, Fire Chief Holtzman, Mr. Hunt, Mr. Lombardi, Mr. Roenigk, Mr. Rose, Ms. Rutkowski, Mr. Schroeder, Ms. Turick
2. **Oath of Office administered by Mayor Berns to:**  
Police Patrol Officer Michael Idov
3. Citizen's Remarks (**City Council limits Citizen's Remarks to three (3) minutes each for a maximum of thirty (30) minutes unless so extended at the discretion of the President or a majority of Council per Council Rules of Procedure, Section 7, Rule 7.2)**  
**(Please see Video Recording for full remarks:**  
<https://www.beachwoodohio.com/528/Live-Stream-Recorded-Meetings>)  
E.J. Bloom  
Ms. Bloom made remarks  
Kyle Fishman  
Mr. Fishman made remarks  
Shana Wallenstein  
Ms. Wallenstein made remarks  
Missy Arbuckle  
Ms. Arbuckie made remarks  
Anthony Brown  
Mr. Brown made remarks  
Larry Coven  
Mr. Coven made remarks  
Jonathan Bannet  
Mr. Bannet made remarks

#### 4. Reports

##### a. Mayor

Mayor Berns congratulated Chief Grispino on his recent award and acknowledged his continued service to the community. He also shared that he will be delivering the State of the City address on Wednesday, March 11th at University Hospitals. Mayor Berns expressed his appreciation to Council for its support in approving funding for the replacement of windows at City Hall.

##### b. Council Members (non-agenda items)

Mr. Isaacson offered remarks regarding the proposed Sheetz rezoning.

Ms. Shoykhet shared that she attended the Tech Dinner Club event and expressed her appreciation to Ms. Biertman for her efforts in making the event possible.

##### c. Department Directors

Mr. Arrietta provided an update on the pool pump replacement project and noted that Phases I and II will be combined and completed following the close of the pool season.

Mr. Schroeder addressed the application process referenced during Citizens' Remarks, noting that applications may be downloaded from the "Local Recreation Go" app. He also shared that pool passes will go on sale April 6th.

Police Chief Grispino acknowledged the passing of a former Beachwood Police Lieutenant and extended condolences to the individual's family.

## Consent Agenda

Approval of Minutes:

**Infrastructure & Public Facilities Committee Meeting held on February 23, 2026**

**Regular City Council Meeting held on February 17, 2026**

## Ordinances

### 1. 2026-8

An Ordinance authorizing and directing the payment of certain claims (Bills) for professional and other services; and declaring this to be an urgent measure

## Motions

1. A Motion authorizing the Clerk of Council to advertise for Bids for the 2026 Road Program per BCO 121.09 and ORC 7.16

2. A Motion authorizing the Clerk of Council to advertise for Bids for the Phase I Signage Project per BCO 121.09 and ORC 7.16

Moved by: P. Smith, Seconded by: A. Stern

### Voice Vote

### On the Suspension:

Yes: 7

No: 0

Abstain: 0

Not Voting: 0

MOTION ADOPTED

### Voice Vote

### On the Adoption:

Yes: 7

No: 0

Abstain: 0

Not Voting: 0

MOTION ADOPTED

**New Business (Regular Agenda)**

**Ordinances**

**1. 2026-9**

An Ordinance authorizing the Director of Finance to transfer Certain Funds from the General Fund (101) to the Capital Improvements Fund (441); and declaring this to be an urgent measure

Moved by: J. DeLong, Seconded by: P. Smith

**Voice Vote**

**On the Suspension:**

Yes: 7  
No: 0  
Abstain: 0  
Not Voting: 0  
MOTION ADOPTED

**Voice Vote**

**On the Adoption:**

Yes: 7  
No: 0  
Abstain: 0  
Not Voting: 0  
MOTION ADOPTED

**2. 2026-10**

An Ordinance amending Beachwood Codified Ordinance Section 121.09 titled "Advertising for Bids; Awarding Contracts"; and declaring this to be an urgent measure

Moved by: A. Jacobs, Seconded by: J. DeLong

**Voice Vote**

**On the Suspension:**

Yes: 7  
No: 0  
Abstain: 0  
Not Voting: 0  
MOTION ADOPTED

**Voice Vote**

**On the Adoption:**

Yes: 7  
No: 0  
Abstain: 0  
Not Voting: 0  
MOTION ADOPTED

**3. 2026-11**

An Ordinance Establishing Fees for Costs associated with Preparing Video Records for Inspection or Production pursuant to Ohio Revised Code Section 149.43(B)(1); and declaring this to be an urgent measure

Moved by: A. Isaacson, Seconded by: D. Shoykhet

**Voice Vote**

**On the Suspension:**

Yes: 7  
No: 0  
Abstain: 0  
Not Voting: 0  
MOTION ADOPTED

**Voice Vote**

**On the Adoption:**

Yes: 7  
No: 0  
Abstain: 0  
Not Voting: 0  
MOTION ADOPTED

**Resolutions**

**1. 2026-31**

A Resolution declaring it necessary to improve Blossom Road between Certain Termini in the City of Beachwood by providing street lighting; and declaring this to be an urgent measure

Moved by: J. Taylor, Seconded by: J. DeLong

**Voice Vote**

**On the Suspension:**

Yes: 7  
No: 0  
Abstain: 0  
Not Voting: 0  
MOTION ADOPTED

**Voice Vote**

**On the Adoption:**

Yes: 7  
No: 0  
Abstain: 0  
Not Voting: 0  
MOTION ADOPTED

**2. 2026-32**

A Resolution declaring it necessary to improve George Zeiger Drive between Certain Termini in the City of Beachwood by providing street lighting; and declaring this to be an urgent measure

Moved by: A. Stern, Seconded by: P. Smith

**Voice Vote**

**On the Suspension:**

Yes: 7  
No: 0  
Abstain: 0  
Not Voting: 0  
MOTION ADOPTED

**Voice Vote**

**On the Adoption:**

Yes: 7  
No: 0  
Abstain: 0  
Not Voting: 0  
MOTION ADOPTED

**3. 2026-33**

A Resolution accepting a Quotation from Dell Marketing LP for the Purchase of Microsoft Office 365, waiving competitive bidding; and declaring this to be an urgent measure

Moved by: A. Jacobs, Seconded by: D. Shoykhet

**Voice Vote**

**On the Suspension:**

Yes: 7  
No: 0  
Abstain: 0  
Not Voting: 0  
MOTION ADOPTED

**Voice Vote**

**On the Adoption:**

Yes: 7  
No: 0  
Abstain: 0  
Not Voting: 0  
MOTION ADOPTED

**4. 2026-34**

A Resolution approving recommended Amendments to the City of Beachwood Civil Service Rules; and declaring this to be an urgent measure

Moved by: P. Smith, Seconded by: J. DeLong

**Voice Vote**

**On the Suspension:**

Yes: 7  
No: 0  
Abstain: 0  
Not Voting: 0  
MOTION ADOPTED

**Voice Vote**

**On the Adoption:**

Yes: 7  
No: 0  
Abstain: 0  
Not Voting: 0  
MOTION ADOPTED

**5. 2026-35**

A Resolution Authorizing the Mayor to enter into a Memorandum of Understanding with the Cuyahoga Soil And Water Conservation District and the Northeast Ohio Regional Sewer District for the Provision of Technical Assistance for the City Of Beachwood's Compliance with the Ohio EPA's National Pollutant Discharge Elimination System ("NPDES") Permit Requirements; and declaring this to be an urgent measure

Moved by: D. Shoykhet, Seconded by: A. Isaacson

**Voice Vote**

**On the Suspension:**

Yes: 7  
No: 0  
Abstain: 0  
Not Voting: 0  
MOTION ADOPTED

**Voice Vote**

**On the Adoption:**

Yes: 7  
No: 0  
Abstain: 0  
Not Voting: 0  
MOTION ADOPTED

**6. 2026-36**

A Resolution authorizing the Mayor to enter into an Agreement with Cleveland Freightliner, Inc. for the Purchase of one (1) Western Star 47X Truck Cab and Chassis and to enter into an Agreement with Concord Road Equipment Mfg., LLC for the Purchase and Installation of one (1) Stainless Steel Dump Body with Snow and Ice Control Package for the Truck; waiving competitive bidding; and declaring this to be an urgent measure

Moved by: A. Stern, Seconded by: J. Taylor

**Voice Vote**

**On the Suspension:**

Yes: 7  
No: 0  
Abstain: 0  
Not Voting: 0  
MOTION ADOPTED

**Voice Vote**

**On the Adoption:**

Yes: 7  
No: 0  
Abstain: 0  
Not Voting: 0  
MOTION ADOPTED

**5. 2026-37**

A Resolution authorizing the Mayor to enter into an Agreement with Cleveland Freightliner, Inc. for the Purchase of one (1) Freightliner M2 106 Plus Cab and Chassis; waiving competitive bidding and to enter into an Agreement with Zoresco Equipment for the purchase of one (1) Construction Utility Body; and declaring this to be an urgent measure

Moved by: J. Taylor, Seconded by: A. Stern

**Voice Vote**

**On the Suspension:**

Yes: 7  
No: 0  
Abstain: 0  
Not Voting: 0  
MOTION ADOPTED

**Voice Vote**

**On the Adoption:**

Yes: 7  
No: 0  
Abstain: 0  
Not Voting: 0  
MOTION ADOPTED

Executive Session discussion to consider confidential information related to the specific business strategy of an applicant for economic development assistance and related to negotiations with other political subdivisions involving requests for economic development assistance, which information is directly related to a request for economic development assistance under Ohio Revised Code Section 5709.41 and involves public infrastructure improvements and the extension of utilities services that are directly related to an economic development project. In the Executive Session it is necessary to protect the interest of the applicant and the possible expenditure of public funds to be made in connection with the economic development project. The second purpose of the Executive Session is to conference with the City Law Director concerning a dispute involving the City that is subject of eminent court action.

Moved by D. Shoykhet, seconded by J. Taylor, at 7:55 P.M. to enter Executive Session.

ROLL CALL:

Yes: Ms. DeLong, Mr. Isaacson, Ms. Jacobs, Ms. Shoykhet, Mr. Smith, Ms. Stern, Ms. Taylor

No: 0

Abstain: 0

Not Voting: 0

Back on the Record at 8:57 P.M.

Adjourn Executive Session at 8:57 P.M.

**Any other matters coming before City Council**

None

**Adjournment**

Adjourn to the next Regular City Council Meeting at 8:58 PM

Approved:

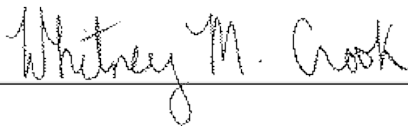

---

Clerk



---

Mayor

Next Regular Council Meeting will be held on: Monday, March 23, 2026 at 7 PM in Council Chambers. For all updates regarding Council Meetings, please visit: [www.BeachwoodOhio.com](http://www.BeachwoodOhio.com)

**Council Members: Danielle Shoykhet - Council President  
Jillian DeLong – Council Vice-President  
Alex Jacobs, Alec Isaacson, P. Smith,  
Ali B. Stern, June E. Taylor  
Clerk of Council: Whitney M. Crook, MMC, CPM**

AN ORDINANCE AUTHORIZING AND DIRECTING THE PAYMENT OF CERTAIN CLAIMS (BILLS) FOR PROFESSIONAL AND OTHER SERVICES; AND DECLARING THIS TO BE AN URGENT MEASURE

BE IT ORDAINED by the Council of the City of Beachwood, State of Ohio, that the Director of Finance is hereby authorized and directed to issue his respective warrants for the following claims, to wit:

Section 1:

<u>For Supplies and Services</u>	<u>March 9th, 2026</u>	<u>\$</u>	<u>20,641.00</u>
Code Consultation	Plan Review Services	\$	1,000.00
Main Event	Camp Invoices	\$	9,392.52
Michael Wildermuth	Plan Review Services	\$	375.00
Perspectus Architecture	Professional Services	\$	9,717.23
Sixmo	Plan Review Services	\$	156.25

Section 2: It is found and determined that all formal actions and deliberation of Council and its committees relating to the passage of this legislation that resulted in formal action were in meetings open to the public where required by Chapter 105 of the Codified Ordinances of the City.

Section 3: This Ordinance is hereby declared an urgent measure immediately necessary for the public peace, health or safety or the efficient operation of the City; and for the further reason that it is necessary to approve said item and/or services available for use at the earliest possible time, to serve the City of Beachwood and its citizens.

WHEREFORE, this Ordinance shall be in full force and effect from and after the earliest date permitted by law.

Attest: I hereby certify that this legislation was duly adopted on the 9th of March 2026 and presented to the Mayor.

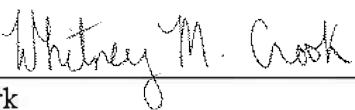
  
Clerk

Approval: I have approved this legislation this 10th day of March 2026 and filed it with the Clerk.

  
Mayor

**RECEIVED**  
FEB 13 2026  
FINANCE DEPT

February 1, 2026

The City of Beachwood  
Accounts Payable  
P.O. Box 22659  
Beachwood, OH 44122

**RE: Building Department Plan Review**

INVOICE FOR PROFESSIONAL SERVICES RENDERED:

Plan review for the month of January 2026 \$1,000.00  
(See attached sheet for breakdown)

**Total amount due** **\$1,000.00**  
**One Thousand Dollars**

Please make check payable to "Code Consultation & Plan Review Services, LLC." Thank you.



Paul Kowalczyk  
Combination Examiner #CE-0000798

**APPROVED FOR PAYMENT**  
BY:   
DATE: 2-3-26  
P/O: \_\_\_\_\_

CODE CONSULTATION & PLAN REVIEW SERVICES, LLC

**City of Beachwood  
Plan Examination Services  
January 2026 Invoice**

Beachwood Plan Review No.:	PK Plan Review No.:	Project:	Time:	Charge:
144782	BW26-01 1/14/26	Beachwood – Vision Expansion 3733 Park Drive, Suite 240 Interior Alterations	4 hours	\$500.00
2025-07595	BW26-02 1/21/26	Goddard School 3875 South Green Road Building Addition – Fire Alarm System	1 hour	\$125.00
146418	BW26-03 1/26/26	U.S. Foot & Ankle Specialists 3733 Park East Drive, Suite 260 Interior Alterations	3 hours	\$375.00
<b>Total:</b>				<b>\$1,000.00</b>

Paul Kowalczyk  
Combination Examiner #CE-000798

**Beachwood Teen Travel Camp - Youth All Access  
(3hr)**

RECEIVED

FEB 05 2026



**Main Event - Avon**  
35605 Chester Rd.  
Avon, OH 44011

FINANCE DEPT

Event Order Q-422475  
Email: avosales@mainevent.com  
Phone: 440-398-0611

Event Date: 6/9/2026  
Start Time: 11:00 AM

Created Date: 1/27/2026  
Date Definite:

APPROVED FOR PAYMENT  
BY: [Signature]  
DATE: 2/4/26  
NO: 26-00495

**INVOICE**

ACCOUNT	PRIMARY CONTACT	EMAIL	PHONE
Beachwood City School District	Shannon Diamond	shannon.diamond@beachwood	12167987614

**Address:**  
24601 Fairmount Boulevard  
Beachwood, Ohio 44122

**EVENT OVERVIEW**

**Package Selection**

DETAILS	QTY.	UOM	PRICE EA.	TOTAL
Youth All Access AM	56	per Guest	\$26.99	\$1,511.44

**Menu**

DETAILS	QTY.	UOM	PRICE EA.	TOTAL
2 Slices of Pizza	56	per Guest	Included	\$0.00

**Activities**

DETAILS	QTY.	UOM	PRICE EA.	TOTAL
All You Can Play Activities 3 Hours	56	per Guest	Included	\$0.00
Bowling Shoes	56	per Guest	Included	\$0.00
\$10 FUNcard	56	per Guest	Included	\$0.00

**Additional Items**

DETAILS	QTY.	UOM	PRICE EA.	TOTAL
Party Street - A La Carte	1	per Hour	\$0.00	\$0.00



**CHARGES & PAYMENTS**

Subtotal	\$1,511.44
Service Charge	\$0.00
Facilitators Fee	\$0.00
Bar Charge	\$0.00
Taxes	Exempt
Grand Total	\$1,511.44
Payments Received	\$0.00
<b>Balance Due</b>	<b>\$1,511.44</b>

# CITY OF Beachwood

## PURCHASE ORDER

Page: 1  
 P.O. Number: 2026-00495  
 P.O. Date: 02/02/2026  
 Req. Number: 26-511-0088-A  
 Requested By: Shannon Diamond  
 Blanket Type:  
 Ship Via:  
 Terms:

**Deliver To** CITY OF BEACHWOOD  
 SHIPPING AND RECEIVING  
 23355 MERCANTILE ROAD  
 BEACHWOOD, OH

**Vendor** 06570  
 Main Event Entertainment, Inc  
 35605 Chester Road  
 Avon, OH 44011

Bill To: Accounts Payable  
 25325 Fairmount Blvd.  
 Beachwood, OH 44122

Line	Description	Account	Qty	Unit	Price/Unit	Amount
	Teen Camp		56		26.9900	\$1,511.44
	Bison Camp		205		26.9900	\$5,532.95
	Sports Camp		87		26.9900	\$2,348.13

Accounting

001	FT 2026	101.512.54420				\$9,392.52
-----	---------	---------------	--	--	--	------------

Page Total: \$9,392.52      Purchase Order Total: \$9,392.52

50% deposit due now  
 Teen Camp June 9  
 Bison camp June 11  
 Sports Camp June 12  
 Balance due Week of trip. Will get updated invoice

**DIRECTOR OF FINANCE CERTIFICATE**

It is hereby certified that the amount required to meet and/or satisfy the contract, agreement, obligation, payment or expenditure for the above has been lawfully appropriated or authorized or directed for such purpose and is in the Treasury or is in the process of collection and is free from any obligation or certification now outstanding.

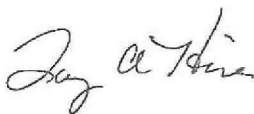

2/2/2026

DIRECTOR OF FINANCE

Date

# Beachwood Bison Camp - Youth All Access (3hr)

**Main Event - Avon**  
 35605 Chester Rd.  
 Avon, OH 44011

**Event Date:** 6/11/2026  
**Start Time:** 11:00 AM

RECEIVED

FEB 05 2026



**Event Order** Q-422485  
**Email:** avosales@mainevent.com  
**Phone:** 440-398-0611

**Created Date:** 1/27/2026  
**Date Definite:**

FINANCE DEPT  
 APPROVED FOR PAYMENT  
 BY: [Signature]  
 DATE: 2/4/26  
 C/O: 26-00495

## INVOICE

ACCOUNT	PRIMARY CONTACT	EMAIL	PHONE
Beachwood City School District	Shannon Diamond	shannon.diamond@beachwood	12167987614

**Address:**  
 24601 Fairmount Boulevard  
 Beachwood, Ohio 44122

### EVENT OVERVIEW

#### Package Selection

DETAILS	QTY.	UOM	PRICE EA.	TOTAL
Youth All Access AM	205	per Guest	\$26.99	\$5,532.95

#### Menu

DETAILS	QTY.	UOM	PRICE EA.	TOTAL
2 Slices of Pizza	205	per Guest	Included	\$0.00

#### Activities

DETAILS	QTY.	UOM	PRICE EA.	TOTAL
All You Can Play Activities 3 Hours	205	per Guest	Included	\$0.00
Bowling Shoes	205	per Guest	Included	\$0.00
\$10 FUNcard	205	per Guest	Included	\$0.00

#### Additional Items

DETAILS	QTY.	UOM	PRICE EA.	TOTAL
Party Street - A La Carte	1	per Hour	\$0.00	\$0.00



**CHARGES & PAYMENTS**

Subtotal	\$5,532.95
Service Charge	\$0.00
Facilitators Fee	\$0.00
Bar Charge	\$0.00
Taxes	Exempt
Grand Total	\$5,532.95
Payments Received	\$0.00
<b>Balance Due</b>	<b>\$5,532.95</b>

# CITY OF Beachwood

## PURCHASE ORDER

**Deliver To** CITY OF BEACHWOOD  
SHIPPING AND RECEIVING  
23355 MERCANTILE ROAD  
BEACHWOOD, OH

**Vendor** 06570  
Main Event Entertainment, Inc  
35605 Chester Road  
Avon, OH 44011

Bill To: Accounts Payable  
25325 Fairmount Blvd.  
Beachwood, OH 44122

Page: 1  
P.O. Number: 2026-00495  
P.O. Date: 02/02/2026  
Req. Number: 26-511-0088-A  
Requested By: Shannon Diamond  
Blanket Type:  
Ship Via:  
Terms:

Line	Description	Account	Qty	Unit	Price/Unit	Amount
	Teen Camp		56		26.9900	\$1,511.44
	Bison Camp		205		26.9900	\$5,532.95
	Sports Camp		87		26.9900	\$2,348.13
Accounting						
001	FT 2026	101.512.54420				\$9,392.52

Page Total: \$9,392.52

Purchase Order Total: \$9,392.52

50% deposit due now  
Teen Camp June 9  
Bison camp June 11  
Sports Camp June 12  
Balance due Week of trip. Will get updated invoice

### DIRECTOR OF FINANCE CERTIFICATE

It is hereby certified that the amount required to meet and/or satisfy the contract, agreement, obligation, payment or expenditure for the above has been lawfully appropriated or authorized or directed for such purpose and is in the Treasury or is in the process of collection and is free from any obligation or certification now outstanding.

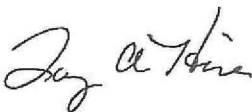

2/2/2026

DIRECTOR OF FINANCE

Date

# Beachwood Sports Camp - Youth All Access (3hr)

**Main Event - Avon**  
35605 Chester Rd.  
Avon, OH 44011

**Event Date:** 6/12/2026  
**Start Time:** 11:00 AM

RECEIVED

FEB 05 2026



FINANCE DEPT

**Event Order Q-422496**  
**Email:** avosales@mainevent.com  
**Phone:** 440-398-0611

**Created Date:** 1/27/2026  
**Date Definite:**

*Handwritten:* 2/4/26  
26-00495

## INVOICE

ACCOUNT	PRIMARY CONTACT	EMAIL	PHONE
Beachwood City School District	Shannon Diamond	shannon.diamond@beachwood	12167987614

**Address:**

24601 Fairmount Boulevard  
Beachwood, Ohio 44122

### EVENT OVERVIEW

**Package Selection**

DETAILS	QTY.	UOM	PRICE EA.	TOTAL
Youth All Access AM	87	per Guest	\$26.99	\$2,348.13

**Menu**

DETAILS	QTY.	UOM	PRICE EA.	TOTAL
2 Slices of Pizza	87	per Guest	Included	\$0.00

**Activities**

DETAILS	QTY.	UOM	PRICE EA.	TOTAL
All You Can Play Activities 3 Hours	87	per Guest	Included	\$0.00
Bowling Shoes	87	per Guest	Included	\$0.00
\$10 FUNcard	87	per Guest	Included	\$0.00

**Additional Items**

DETAILS	QTY.	UOM	PRICE EA.	TOTAL
Party Street - A La Carte	1	per Hour	\$0.00	\$0.00



**CHARGES & PAYMENTS**

Subtotal	\$2,348.13
Service Charge	\$0.00
Facilitators Fee	\$0.00
Bar Charge	\$0.00
Taxes	Exempt
Grand Total	\$2,348.13
Payments Received	\$0.00
<b>Balance Due</b>	<b>\$2,348.13</b>



**PURCHASE ORDER**

Page: 1  
P.O. Number: 2026-00495  
P.O. Date: 02/02/2026  
Req. Number: 26-511-0088-A  
Requested By: Shannon Diamond  
Blanket Type:  
Ship Via:  
Terms:

**Deliver To** CITY OF BEACHWOOD  
SHIPPING AND RECEIVING  
23355 MERCANTILE ROAD  
BEACHWOOD, OH

**Vendor** 06570  
Main Event Entertainment, Inc  
35605 Chester Road  
Avon, OH 44011

Bill To: Accounts Payable  
25325 Fairmount Blvd.  
Beachwood, OH 44122

Line	Description	Account	Qty	Unit	Price/Unit	Amount
	Teen Camp		56		26.9900	\$1,511.44
	Bison Camp		205		26.9900	\$5,532.95
	Sports Camp		87		26.9900	\$2,348.13
Accounting						
001	FT 2026	101.512.54420				\$9,392.52

Page Total: \$9,392.52

Purchase Order Total: \$9,392.52

50% deposit due now  
Teen Camp June 9  
Bison camp June 11  
Sports Camp June 12  
Balance due Week of trip. Will get updated invoice

**DIRECTOR OF FINANCE CERTIFICATE**

It is hereby certified that the amount required to meet and/or satisfy the contract, agreement, obligation, payment or expenditure for the above has been lawfully appropriated or authorized or directed for such purpose and is in the Treasury or is in the process of collection and is free from any obligation or certification now outstanding.

2/2/2026

DIRECTOR OF FINANCE

Date

RECEIVED  
FEB 13 2026  
FINANCE DEPT



MICHAEL H. WILDERMUTH, AIA, ARCHITECT

January 5, 2026

The City of Beachwood  
Accounts Payable Department  
P.O. Box 22659  
Beachwood, Ohio 44122

Re: Building Department  
**INVOICE**  
Plan Review Services for January 2026

Invoice for professional services rendered for the review of plans for compliance with the Ohio Building Code.

Plan Review for the month of January 2026..... \$375.00  
Cost Breakdown Sheet Attached

**Total amount due.....\$375.00**

Respectfully,

*Michael H. Wildermuth*

Michael H. Wildermuth, AIA  
Master Plans Examiner

APPROVED FOR PAYMENT  
\_\_\_\_\_  
DATE: 2-9-26  
P/O: \_\_\_\_\_

38255 RIDGE ROAD WILLOUGHBY, OHIO 44094 440-946-1061/ C 440-749-1877  
mhwildermuth@oh.rr.com



MICHAEL H. WILDERMUTH, AIA, ARCHITECT  
Beachwood Plan Review

Jan. 2026 Beachwood Plan Review				
MHW	Beachwood	Job Name	Time	
Job No	Receipt No.			
CB2601-1 1/19/2026	CBLDALT2026- 04	3733 Park East Spinal Injury and Pain Recovery	3.0 H	\$375.00
		<b>Total</b>	<b>3.0 H</b>	<b>\$375.00</b>

RECEIVED

FEB 11 2026

FINANCE DEPT

APPROVED FOR PAYMENT

Perspectus Architecture  
 1300 East 9th Street, Suite 910  
 Cleveland, OH 44114  
 (216) 752-1800

BY: C. Comitta

DATE: 2/13/26

P/O: 2025-01161

City of Beachwood  
 Accounts Payable  
 25325 Fairmount Boulevard  
 Beachwood, OH 44122

Invoice number 23387  
 Date 02/09/2026

Project 24135 CITY OF BEACHWOOD - CITY HALL GLAZING REPLACEMENT

Professional Services through 01/31/2026

Description	Contract Amount	Percent Complete	Prior Billed	Total Billed	Remaining	Current Billed
<b>Basic Services</b>						
Schematic Design/Design Development	5,250.00	100.00	5,250.00	5,250.00	0.00	0.00
Construction Documents	5,125.00	100.00	5,125.00	5,125.00	0.00	0.00
Bidding/Construction Phase Services	5,125.00	70.00	3,075.00	3,587.50	1,537.50	512.50
Subtotal	15,500.00	90.08	13,450.00	13,962.50	1,537.50	512.50
Total	15,500.00	90.08	13,450.00	13,962.50	1,537.50	512.50

Invoice total 512.50

**Aging Summary**

Invoice Number	Invoice Date	Outstanding	Current	Over 30	Over 60	Over 90	Over 120
23387	02/09/2026	512.50	512.50				
	Total	512.50	512.50	0.00	0.00	0.00	0.00

APPROVED FOR PAYMENT

Perspectus Architecture  
1300 East 9th Street, Suite 910  
Cleveland, OH 44114  
(216) 752-1800

BY: C. Amato  
DATE: 2/13/26  
P/O: 2025-02397

City of Beachwood  
Jennifer Twitt  
25325 Fairmount Boulevard  
Beachwood, OH 44122

Invoice number 23388  
Date 02/09/2026

Project 24118 CITY OF BEACHWOOD PUBLIC  
WORKS ROOF REPLACEMENT

Professional Services through 01/31/2026

Description	Contract Amount	Percent Complete	Prior Billed	Total Billed	Remaining	Current Billed
<b>Basic Services</b>						
Schematic Design / Design Development	38,400.00	100.00	38,400.00	38,400.00	0.00	0.00
Construction Documents	23,040.00	100.00	23,040.00	23,040.00	0.00	0.00
Bidding / Construction	15,360.00	100.00	15,360.00	15,360.00	0.00	0.00
Subtotal	76,800.00	100.00	76,800.00	76,800.00	0.00	0.00
<b>Scope Change Authorizations</b>						
Bidding	5,400.00	100.00	5,400.00	5,400.00	0.00	0.00
SCA 01 - Bidding	9,200.00	100.00	0.00	9,200.00	0.00	9,200.00
Subtotal	14,600.00	100.00	5,400.00	14,600.00	0.00	9,200.00
Total	91,400.00	100.00	82,200.00	91,400.00	0.00	9,200.00

**Reimbursable Expenses**

Reimbursables

	Date	Units	Cost Rate	Cost Amount	Multiplier	Rate	Billed Amount
Printing	01/31/2026			4.30	1.10		4.73
				Phase subtotal			4.73

Invoice total **9,204.73**

**Aging Summary**

Invoice Number	Invoice Date	Outstanding	Current	Over 30	Over 60	Over 90	Over 120
23388	02/09/2026	9,204.73	9,204.73				
	Total	9,204.73	9,204.73	0.00	0.00	0.00	0.00



# Invoiced printing for 24118 City of Beachwood Public Works Roof Replacement

Jan 1, 2026 to Jan 31, 2026.

Size	Duplex	Color Pages	Grayscale Pages	Total Printed Pages	Jobs	Cost
------	--------	-------------	-----------------	---------------------	------	------

## int: 24118 City of Beachwood Public Works Roof Replacement

{(ANSLA)	Simplex	0	3	3	1	\$0.30
{(ANSLA)	Duplex	0	40	40	1	\$4.00
<b>for account "24118 City of Beachwood Public Works Roof Replacement":</b>						<b>\$4.30</b>
<b>Totals:</b>						<b>\$4.30</b>



RECEIVED  
FEB 13 2026  
FINANCE DEPT

# Invoice

Date 1/31/2026  
Invoice # PE1235

**Remit Payment to :**

Sixmo Architecture  
204 Front Street  
Marietta, OH 45750

**Bill To**

City of Beachwood  
25325 Fairmount Blvd  
Beachwood, OH 44122

**Project**

Beachwood Plan Exams 2026

**For questions regarding this invoice :**

Contact Sheree Wilson at 740-809-2400 ext. 118

**P.O. Number                      Payment Terms**

Net 30

Description	Prior Billed	Current Billing
CBLDAL-2026-3 - UH Ahuja New CT Suite		156.25

Total Due : **\$156.25**

**APPROVED FOR PAYMENT**

BY: [Signature]

DATE: 2-3-26

P/O: \_\_\_\_\_



---

**PLAN EXAMINATION FEE CALCULATION**

*City of Beachwood*

*25325 Fairmount Blvd*

*Brian Roenigk, Building Commissioner*

---

Plan Review / Invoice No.: CBLDALT-2026-3

Plans Examiner: Patrick E. Thornton, Combination Examiner, CE-001499  
Remit Payment to: **SIXMO Architecture 204 Front Street, Marietta, Ohio 45750**

Date of Initial Review: January 29, 2026

Project Name: UH Ahuja New CT Suite  
Project Address: 3999 Richmond Road  
Project Description: Alterations  
Area of Work: 396 sq. ft.

---

**Initial Submittal:**

Initial Review Date: January 29, 2026

1.25 hours @ \$125.00 \$ 156.25

Estimated Reimbursables: \$ \_\_\_\_\_

Sub-Total \$ 156.25

---

**Subsequent Review:**

Review Date: \_\_\_\_\_

\_\_\_\_\_ hours @ \$125.00 \$ \_\_\_\_\_

Estimated Reimbursables: \$ \_\_\_\_\_

Sub-Total \$ 0.00

---

**Current Grand Total** \$ 156.25

---

## Motion

### MEMORANDUM

To: Justin Berns, Mayor  
Chris Arrietta, Director of Public Works

From: Joseph R. Ciuni P.E. P.S.  
City Engineer

**Re: 2026 Road Program**

We hereby request permission to go out for bids to select a contractor for the 2026 Road Program. The scope of work is as follows:

1. Resurface North Woodland - \$500,000
2. Resurface Meadowway Drive - \$ 90,000
3. Large Area Asphalt Patching of Shaker Blvd. - \$125,000 (\$62,500 to be reimbursed by County)
4. Repair and Resurface PW Dept. East Parking Lot - \$360,000 (asphalt)

Total Cost = \$1,075,000 (construction) + \$25,000 (Engineering) = \$1,100,000.

**Motion Adopted March 9, 2026**

**CITY OF BEACHWOOD**  
**INTER-OFFICE MEMORANDUM**

---

**TO:** Members of City Council

**FROM:** Justin B. Berns, Mayor 

**DATE:** March 6, 2026

**SUBJECT:** Request for Authorization to Bid – Phase I Signage Project

The City previously initiated a comprehensive signage program to establish a cohesive wayfinding and identity system for major City facilities and destinations. The effort began several years ago and resulted in the installation of the Changeable Copy Sign at the corner of Richmond and Fairmount, which was designed by Guide Studios.

Guide Studios also developed a broader signage package that includes a variety of sign types intended to guide residents and visitors to key city locations. The package was designed so the City can implement signage improvements in phases as funding allows.

We are now prepared to move forward with **Phase 1** of the signage project and are requesting Council's authorization to bid the project. Phase 1 will include:

- 3 City Park Signs, including the new Gorden Gateway Park Sign
- City Hall and Community Center identification signage
- Directional signage for the City Hall parking lot

The bid package will also include two alternate items:

- Fire Station 1 signage
- Commerce Park – Chagrin signage

This project is estimated at approximately **\$90,000**, excluding the alternate bid items. We respectfully request authorization from City Council to proceed with bidding for Phase 1 of the City Signage Project.

Thank you for your consideration.

Cc: Todd Hunt, Law Director  
Larry Heiser, Finance Director  
Chris Arrietta, Public Works Director  
Tina Turick, City Administrator  
Brittany Rutkowski, Mayor's Executive Assistant  
Whitney Crook, Clerk of Council

**Motion Adopted March 9, 2026**

AN ORDINANCE AUTHORIZING THE DIRECTOR OF FINANCE TO TRANSFER CERTAIN FUNDS FROM THE GENERAL FUND (101) TO THE CAPITAL IMPROVEMENTS FUND (441); AND DECLARING THIS TO BE AN URGENT MEASURE

WHEREAS, based upon the recommendation of the Finance Director, this Council desires to transfer Three Million Five Hundred Thousand Dollars and No/Cents (\$3,500,000.00) from the General Fund (101) to the Capital Improvements Fund (441).

NOW, THEREFORE, BE IT ORDAINED by the Council of the City of Beachwood, County of Cuyahoga, and State of Ohio, that:

Section 1: The Finance Director is hereby authorized and directed to transfer Three Million Five Hundred Thousand Dollars and No/Cents (\$3,500,000.00) from the General Fund (101) to the Capital Improvements Fund (441).

Section 2: It is found and determined that all formal actions and deliberations of Council and its committees, relating to the passage of this legislation that resulted in formal action were in meetings open to the public where required by Chapter 105 of the Codified Ordinances of the City.

Section 3: This Ordinance is declared to be an urgent measure necessary for the preservation of the public peace, health, safety, or the efficient operation of the City; and for the further reason that the transfer of funds authorized herein is needed to ensure the timely payment of expenses and proper functioning of City departments; wherefore, this Ordinance shall be in full force and effect immediately upon its passage and approval by the Mayor.

Attest: I hereby certify this legislation was duly adopted on the 9<sup>th</sup> day of March, 2026, and presented to the Mayor for approval or rejection in accordance with Article III, Section 8 of the Charter on the 10<sup>th</sup> day of March, 2026.

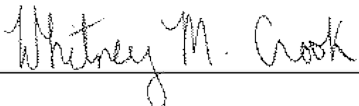
  
\_\_\_\_\_  
Clerk

Approval: I have approved this legislation this 10<sup>th</sup> day of March, 2026 and filed it with the Clerk.

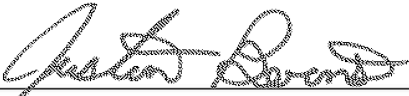
  
\_\_\_\_\_  
Mayor

Approved 2/18/2026

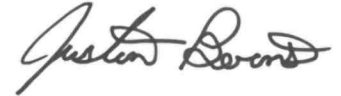

**CITY OF BEACHWOOD  
FINANCE DEPARTMENT  
INTER-OFFICE COMMUNICATION**

---

**TO:** Mayor Justin Berns, Finance Chair Jillian DeLong  
**FROM:** Larry Heiser, Finance Director *LH*  
**DATE:** February 13, 2026  
**SUBJECT:** Transfer to Capital Projects Fund

The 2026 Budget included \$3,500,000 in transfers into the Capital Projects Fund. I would like to have approved transferring the \$3,500,000 from the General Fund (101) to the Capital Improvements Fund (441) at the next available Council meeting.

Please call or email if you have any questions.

AN ORDINANCE AMENDING BEACHWOOD CODIFIED ORDINANCE SECTION 121.09 TITLED “ADVERTISING FOR BIDS; AWARDING CONTRACTS”; AND DECLARING THIS TO BE AN URGENT MEASURE

WHEREAS, City Council has previously adopted Beachwood Codified Ordinance Section 121.09 titled, “Advertising for Bids; Awarding Contracts”, governing competitive bidding and related procedures;

WHEREAS, Council desires to revise the competitive bidding threshold for expenditures for goods and services to amounts over seventy-five thousand dollars (\$75,000.00) from the current threshold of fifty thousand dollars;

WHEREAS, Council further desires to amend the advertisement provisions for competitive bidding to be more efficient and timely in the procurement of necessary goods and services.

NOW, THEREFORE, BE IT ORDAINED by the Council of the City of Beachwood, Cuyahoga County, State of Ohio, that:

Section 1: Council hereby amends Beachwood Codified Ordinance Section 121.09 titled, “Advertising for Bids; Awarding Contracts”, to read and provide, in its entirety, as set forth in **Exhibit “A”** which is attached hereto and fully incorporated by reference herein.

Section 2: Existing Beachwood Codified Ordinance Section 121.09 (a)(1) is hereby repealed.

Section 3: This Council finds and determines that all formal actions of this Council and any of its committees concerning and relating to the passage of this Ordinance were taken in an open meeting of this Council or committees, and that all deliberations of this Council and any of its communities that resulted in those formal actions were in meetings open to the public, all in compliance with the law.

Section 4: This Ordinance is declared to be an urgent measure necessary for the preservation of the public peace, health, safety, or the efficient operation of the City, and for the further that immediate implementation of the updated competitive bidding threshold and advertising procedures is required to ensure more efficient and timely bidding, contracting, and completion of municipal projects and expenditures; wherefore, this Ordinance shall be in full force and effect immediately upon its passage and approval by the Mayor.

Attest:

I hereby certify this legislation was duly adopted on the 9<sup>th</sup> day of March, 2026, and presented to the Mayor for approval or rejection in accordance with Article III, Section 8 of the Charter on the 10<sup>th</sup> day of March, 2026.

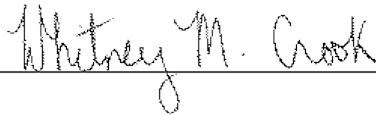
  
\_\_\_\_\_

Clerk

Approval:

I have approved this legislation this 10<sup>th</sup> day of March, 2026 and filed it with the Clerk.

  
\_\_\_\_\_

Mayor

**CITY OF BEACHWOOD  
FINANCE DEPARTMENT  
INTER-OFFICE COMMUNICATION**

---

**TO:** Mayor Justin Berns, Finance Chair Jillian DeLong, Council President  
Danielle Shoykhet  
**FROM:** Larry Heiser, Finance Director *LHH*  
**DATE:** February 18, 2026  
**SUBJECT:** Bidding requirements RC 9.17 and ORC 307.86

All: Below is the change to Orc 9.17 which became effective starting in 2024. The former bid threshold was \$50,000 which based upon rising costs was changed to \$75,000 with a yearly 3% escalator. With the increase of pricing of materials and services I am requesting that Council approves the change to follow ORC 9.17 and increase the bidding threshold accordingly. This is not an increase in the Mayor's spending authority and all items above the Mayor's spending limit will still need Council approval. The City would still be looking to get competitive pricing from vendors above the \$25,000 to the \$75,000 limit as we currently operate. Additionally, ORC 307.86 regulates notice of bidding and the avenues to advertise. We would like to adopt wording similar ORC 307.86 and our own code 1107.01 wording for bidding as advertising in a newspaper is less and less effective and costly as well as delays in bidding dates. With your approval we would like to introduce legislation at the next available Council meeting. Please find the relative code sections below:

ORC 9.17 Competitive bidding threshold amount:

- A) The amount for purposes of a provision of the Revised Code that references this section shall be as follows:
- 1) Beginning on the effective date of this section through calendar year 2024, seventy-five thousand dollars;
  - (2) For each calendar year thereafter, the amount for the previous calendar year increased by three per cent as determined and published by the director of commerce.

ORC 307.86 Notice of competitive bidding:

Where competitive bidding is required by section 307.86 of the Revised Code, notice thereof shall be given in the following manner:

- (A) Notice shall be published once a week for not less than two consecutive weeks preceding the day of the opening of bids for any purchase, lease, lease with option or agreement to purchase, or construction contract in excess of the amount specified in section 9.17 of the Revised Code, using at least one of the following methods:
- (1) In the print or digital edition of a newspaper of general circulation within the county;
  - (2) On the official public notice website established under section 125.182 of the Revised Code;
  - (3) On the website and social media account of the county.

(B) Notices shall state all of the following:

- (1) A general description of the subject of the proposed contract and the time and place where the plans and specifications or itemized list of supplies, facilities, or equipment and estimated quantities can be obtained or examined;
- (2) The time and place where bids will be opened;
- (3) The time and place for filing bids;
- (4) The terms of the proposed purchase;
- (5) Conditions under which bids will be received.

1107.01 Amendment procedure. Council may amend the zoning regulations and rezone property within the City on its own motion, or at the request of a property owner or owner's agent, with the following procedure. Every proposed amendment shall be submitted to the Council first for its initial consideration. Proposed amendments, prior to adoption, shall be referred to the Commission for a report and recommendation. Upon receipt of the report and recommendation of the Commission, the Council shall conduct a public hearing. Public notice of the hearing shall be published on the City's official website and on the City's official social media pages and electronic changeable copy sign for a period of not less than thirty (30) days prior to the date of the hearing. In addition, in the situation of a proposed amendment to the Zone Map designation of a zoning district to be applied to a parcel or parcels, written notice of the public hearing shall be delivered to all Adjoining Property owners, as defined herein, by a nationally recognized delivery service or by hand-delivery, with delivery made no less than ten (10) days prior to the public hearing date.

Please call or email if you have any questions.

## EXHIBIT A

### 121.09 Advertising for bids; awarding contracts.

(a) (1) Unless specifically waived by Council, contracts for the expenditure of more than seventy-five thousand dollars (\$75,000.00) shall be awarded pursuant to competitive bidding. The advertising for bids shall be made by a motion of Council Notices of bid advertisements or other solicitations for competitive bidding shall be placed, on a timely basis, with a reasonable period allowed for response by any one or more of the following means: at least once in any of the following: a newspaper of general circulation within the City, on the City's website, or on any other website or other means accessible to the public. The Clerk shall be solely responsible for receipt and opening of all City bids. The award of a contract accepting a bid shall be made by ordinance or resolution of Council directing the Mayor and Finance Director to enter into an appropriate contract.

- (2) If an ordinance or resolution directing the Mayor and Finance Director to enter into an appropriate contract with a successful bidder is approved by Council in accordance with the procedure outlined above in (a)(i) of this section, and such contract is in fact executed by the City, and if, during the performance of an awarded contract it should become apparent that a change order or alteration is necessary to the original contract, in an amount in excess of twenty-five thousand dollars and no/cents (\$25,000.00), such change order or alteration must first be authorized by Council. The need for the change order or alteration shall be presented to Council by ordinance or resolution. If the change order or alteration to an existing contract is twenty-five thousand dollars and no/cents (\$25,000.00) or less, the Mayor is authorized to enter into such supplemental agreement without Council's authorization. Such amounts shall be cumulative and shall not be offset by non-performed items or other credits.
- (b) Contracts for expenditures of twenty-five thousand dollars (\$25,000.00) or more, but not more than seventy-five thousand dollars (\$75,000.00) are not required to be subject to competitive bidding, but may be awarded, upon the recommendation of the Mayor and/or Department Director, by ordinance or resolution of Council directing the Mayor and Finance Director to enter into an appropriate contract.
- (c) Pursuant to Ohio R.C. 125.04, the City may also participate in the cooperative purchasing program through the State Department of Administrative Services, pursuant to such terms and conditions as the State prescribes without advertising further for competitive bids. Pursuant to the provisions of Ohio R.C. 125.04(C), the City may also purchase supplies or services available through the State Cooperative Purchasing Program from another party, if such supplies or services can be obtained upon equivalent terms, conditions and specifications, but at a lower price, than such supplies or services can be obtained through the State Cooperative Purchasing Program, without following any competitive selection procedures otherwise required by law. The Finance Department shall maintain sufficient information regarding a purchase made pursuant to this authorization to verify that the City satisfied the conditions for making such purchase without competitive bidding.
- (1) Blanket Purchase Orders. In accordance with Ohio Revised Code Section 5705.41(D), the Finance Director is hereby authorized to issue blanket purchase orders in an amount not to exceed fourteen thousand nine hundred ninety-nine dollars and ninety-nine cents (\$14,999.99) per line item, provided that the blanket purchase orders cannot extend beyond the fiscal year-end, although they may remain open after year-end to pay for obligations incurred prior to year end. The total amount of blanket purchase orders issued for the year against a particular line item

appropriation may exceed fourteen thousand nine hundred ninety-nine dollars and ninety-nine cents (\$14,999.99), provided that adequate funds were appropriated, and no more than fourteen thousand nine hundred ninety-nine dollars and ninety-nine cents (\$14,999.99) was spent with any one vendor, unless approved by Council, or purchases are being made under the cooperative purchasing program through the State Department of Administrative Services, or at a price lower than the pricing offered through the state program.

- (d) (1) The City may participate in contracts authorized by the Equalis Cooperative purchasing program, Sourcewell, the National Association of State Procurement Officials ("NASPO") cooperative purchasing program, the General Services Administration ("GSA") cooperative purchasing program, other State of Ohio cooperative purchasing programs and the Interlocal Purchasing System (TIPS Purchasing Cooperative) in order for the City to purchase equipment, materials, supplies and other articles that have been competitively bid in accordance with participating cooperative purchasing programs.
  - (2) The Mayor is authorized to agree, in the name of the City, to be bound by all terms and conditions that the Equalis Cooperative purchasing program, Sourcewell, the National Association of State Procurement Officials ("NASPO") cooperative purchasing program, the General Services Administration ("GSA") cooperative purchasing program, the Interlocal Purchasing System (TIPS Purchasing Cooperative), and other State of Ohio cooperative purchasing programs prescribes.
  - (3) The Mayor is authorized to agree, in the name of the City, to directly pay any vendor, under contract with the Equalis Cooperative purchasing program, Sourcewell, the National Association of State Procurement Officials ("NASPO") cooperative purchasing program, the General Services Administration ("GSA") cooperative purchasing program, the Interlocal Purchasing System (TIPS Purchasing Cooperative) and other State of Ohio cooperative purchasing programs in which the City participates, for those items that the City receives pursuant to the contract.
- (e) (1) Offers of sponsorship, in-kind donations or donation of cash or items valued up to twenty-five thousand dollars and no/cents (\$25,000.00) may be accepted by the Mayor.
  - (2) Offers of sponsorships, in-kind donations or donations of cash or items valued more than twenty-five thousand dollars and no/cents (\$25,000.00) must be accepted by City Council.

AN ORDINANCE ESTABLISHING FEES FOR COSTS ASSOCIATED WITH PREPARING VIDEO RECORDS FOR INSPECTION OR PRODUCTION PURSUANT TO OHIO REVISED CODE SECTION 149.43(B)(1); AND DECLARING THIS TO BE AN URGENT MEASURE

WHEREAS, Ohio Revised Code Section 149.43(B)(1) authorizes a state or local law enforcement agency to charge a requester of public records the actual cost associated with preparing a video record for inspection or production, not to exceed seventy-five dollars (\$75.00) per hour of video produced, nor seven hundred fifty dollars (\$750.00) total; and

WHEREAS, said statute further authorizes a state or local law enforcement agency to require that a requester pay the estimated actual cost for inspection or production before the process of preparing the video record begins; and

WHEREAS, the intention of this law is to help law enforcement agencies cover the administrative costs associated with the proper editing or redacting video records for public inspection or release; and

WHEREAS, the City of Beachwood is responsible for processing and redacting video footage in response to public records requests and utilizes various public records management systems to process public records requests, which require staffing, time, financial and other resources to comply with state law; and

WHEREAS, requests for video footage have significantly increased in volume year over year and the tools required to produce said requests have become a substantial expense for the City; and

WHEREAS, monies collected as a result of this Ordinance will alleviate and help offset the costs associated with maintaining and operating the City's public records management systems utilized to fulfill such requests.

NOW, THEREFORE, BE IT ORDAINED by the Council of the City of Beachwood, County of Cuyahoga, and State of Ohio, that:

Section 1: Council hereby authorizes the City to charge a requester the actual cost associated with preparing, editing, or redacting a video record for inspection or production in response to a public records request, as provided by Ohio Revised Code Section 149.43(B)(1).

Section 2: The charge shall not exceed seventy-five dollars (\$75.00) per hour of video produced, nor a total of seven hundred fifty dollars (\$750.00) per request.

Section 3: Prior to beginning the process of preparing, editing, or redacting a video record, the Law Department may require payment of the estimated actual cost. Upon completion, if the actual cost is less than the estimated amount paid, the City shall refund the difference; if the

actual cost exceeds the estimate, the requester shall pay the remaining balance before release.

Section 4: "Actual cost" shall include, but is not limited to, the cost of employee time spent preparing, redacting, reviewing, or producing the video record; the prorated use of records management systems such as JustFOIA and Veritone; and any related media, storage, or administrative costs.

Section 5: The City's Public Records Policy shall be amended to include the provisions established in this Ordinance. The City's Records Manager, in coordination with the Law Department, shall ensure that the amended policy is distributed and made available in accordance with Ohio law.

Section 6: The Finance Department is authorized to establish appropriate accounting procedures to record and process payments received under this Ordinance, and the Law Department shall maintain documentation to substantiate all charges.

Section 7: All payments made to the City resulting from this Ordinance shall be placed in the General Fund.

Section 8: It is found and determined that all formal actions and deliberations of Council and its committees relating to the passage of this legislation that resulted in formal action were in meetings open to the public where required by Chapter 105 of the Codified Ordinances of the City.

Section 9: This Ordinance is declared to be an urgent measure necessary for the public peace, health, safety, or the efficient operation of the City; and for the further reason to ensure the City may immediately recover costs associated with fulfilling video record requests; wherefore, this Ordinance shall be in full force and effect immediately upon its passage and approval by the Mayor.

Attest: I hereby certify this legislation was duly adopted on the 9th day of March, 2026, and presented to the Mayor for approval or rejection in accordance with Article III, Section 8 of the Charter on the 10th day of March, 2026.

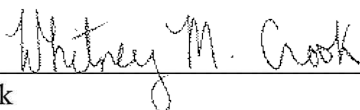
  
\_\_\_\_\_  
Clerk

Approval: I have approved this legislation this 10th day of March, 2026 and filed it with the Clerk.

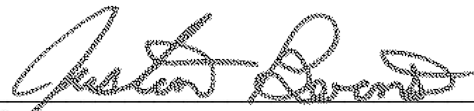
  
\_\_\_\_\_  
Mayor

A RESOLUTION DECLARING IT NECESSARY TO IMPROVE BLOSSOM ROAD BETWEEN CERTAIN TERMINI IN THE CITY OF BEACHWOOD, OHIO, BY PROVIDING STREET LIGHTING; AND DECLARING THIS TO BE AN URGENT MEASURE

WHEREAS, the City has previously authorized and requested The Cleveland Electric Illuminating Company, the City Engineer, and the Finance Director to prepare plans, profiles, specifications and an estimate of cost for the improvement described in Section 1 below;

NOW, THEREFORE, BE IT RESOLVED by the Council of the City of Beachwood, County of Cuyahoga, and State of Ohio, that:

Section 1. It is declared necessary to improve Blossom Road from Timberlane Road to the southerly terminus of Blossom Road by providing street lighting for a period of five years with seven underground-fed, 100-watt high pressure sodium post top lamps.

Section 2. The specifications and estimate of cost of the improvement now on file in the office of the Clerk of the Council are approved.

Section 3. This Council finds and determines that: (i) the improvement is conducive to the public health, convenience and welfare of this City and the inhabitants thereof and (ii) the lots and lands to be assessed as described in Section 4 hereof are specially benefited by the improvement.

Section 4. The whole cost of the improvement, less 2% of that cost, there being no intersections, shall be assessed in proportion to the benefits which may result from the improvement upon the lots and lands bounding and abutting upon Blossom Road between the termini described in Section 1 hereof.

Section 5. The cost of the improvement shall include all costs of the annual amount charged by The Cleveland Electric Illuminating Company for providing electricity, the cost of specifications and estimates and of printing, serving and publishing notices, resolutions and ordinances, the costs incurred in connection with the preparation, levy and collection of the special assessments, the cost of obtaining legal descriptions and title insurance in connection with the determination of title to the properties to be assessed for the improvement, expenses of legal services, and cost of labor and material, together with all other necessary expenditures. The Finance Director is authorized to advance moneys for the cost of the special assessments from available funds.

Section 6. The Finance Director is authorized and directed to prepare and file in the office of the Clerk of the Council the estimated special assessments of the cost of the improvement described in this Resolution. Those estimated special assessments shall be based upon the estimate of cost of the improvement now on file in the office of the Clerk of the Council and shall be prepared pursuant to the provisions of this Resolution. When the estimated special assessments have been so filed, the Clerk of the Council shall cause notice of the adoption of this Resolution and the filing of the estimated special assessments to be served in the manner provided by law on the owners of all lots and lands to be assessed.

Section 7. The special assessments to be levied shall be paid according to the following payment schedule: in five annual installments, with interest at the rate or rates determined by Council when it passes the assessing ordinance levying those special assessments on the unpaid amount of such special assessments; provided that the owner of any property assessed may pay the special assessment in cash within 30 days after passage of the assessing ordinance.

Section 8. The special assessments to be levied may be levied and collected before the improvement is commenced or completed.

Section 9. Bonds or notes of the City shall not be issued in anticipation of the levy or collection of the special assessments. The remainder of the cost of the improvement after application of the special assessments shall be paid from other available funds of the City.

Section 10. In the event that after the special assessments are certified to the County Auditor for collection: (i) the annual amount charged by The Cleveland Electric Illuminating Company for providing electricity is increased or (ii) the City is required to advance, from funds other than special assessments collected, moneys to pay the annual amount charged by The Cleveland Electric Illuminating Company for providing electricity, the Clerk of the Council is authorized to calculate and determine the resulting increase in the special assessment against each property, including interest on the moneys advanced, at the rate or rates determined by Council when it passes the assessing ordinance. The increased special assessments shall be in proportion to the original special assessments certified to the County Fiscal Officer. The Clerk of the Council shall cause notice of the resulting increases to be served on the owners of all lots and lands assessed in the manner set forth in Ohio Revised Code Section 727.13 for service of notice of the passage of a resolution of necessity and the filing of the estimated assessments. Any owner of a lot or parcel who objects to the amount of the increased special assessments shall file such objection in writing with the Clerk of the Council within two weeks from the date of completion of the notice required under this section. Such objection shall include the address for mailing of the notice of the meeting of the assessment equalization board hereinafter provided for. An owner who fails to so file an objection shall be deemed to have waived any objection. In the event any objections are received and in the event Council does not provide for another procedure, Council shall appoint an assessment equalization board, consisting of three disinterested freeholders of the City to hear the objections and shall fix the time and place of such hearing. Such notice shall be mailed at least five days before the date of such hearing. The assessment equalization board shall have the powers and duties of an assessment equalization board set forth in Ohio Revised Code Section 727.17. Council may approve or disapprove the report, including any changes recommended by the board in the estimated assessments. In the event Council disapproves the report of the board it shall appoint a new board and shall fix the time and place for the hearing by such board of objections. Such new board shall have the same powers and duties and shall proceed in the same manner as the original board. When Council has approved the report, the Clerk of the Council shall certify the corrected special assessments to the County Fiscal Officer.

Section 11. It is found and determined that all formal actions and deliberations that resulted in formal actions of Council and its committees, relating to the adoption of this Resolution, were in meetings open to the public in compliance with all Beachwood requirements.

RESOLUTION NO. 2026-31

Section 12. This Resolution is declared to be an urgent measure necessary for the public peace, health, safety, or the efficient operation of the City; and for the further reason that the immediate provision for lighting of said public street is necessary for safer and more convenient travel upon said street; wherefore, this Resolution shall be in full force and effect immediately upon its passage and approval by the Mayor.

Attest: I hereby certify this legislation was duly adopted on the 9<sup>th</sup> day of March, 2026, and presented to the Mayor for approval or rejection in accordance with Article III, Section 8 of the Charter on the 10<sup>th</sup> day of March, 2026.

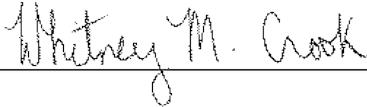
  
\_\_\_\_\_  
Clerk

Approval: I have approved this legislation this 10<sup>th</sup> day of March, 2026 and filed it with the Clerk.

  
\_\_\_\_\_  
Mayor

**CITY OF BEACHWOOD**  
**FINANCE DEPARTMENT**  
**INTER-OFFICE COMMUNICATION**

---

**TO:** Mayor Justin Berns  
**FROM:** Larry A. Heiser, Finance Director *LAH*  
**RE:** Street Lighting Blossom Lane and George Zeiger  
**DATE:** February 24, 2026

Every 5 years the City must reassess Blossom Drive residents and George Zeiger Drive Businesses for street lighting. Blossom Lane: the calculation for the 2026 assessments is \$672.28 per resident cost for 5 years. This represents a monthly cost of \$11.20 for each parcel. I have built in a slight escalator of 3% to cover any increases over the next 5-year period. As Council may recall I requested a \$2,000 transfer into the Blossom Fund in 2025 due to the fact that collections for the 2021 assessments did not appear to generate enough revenue to pay the relative invoices for Blossom. If we run a slight surplus moving forward, I would advocate after 4 years to transfer monies back to the General Fund from the Blossom Drive Fund (261).

George Zeiger: Due to the actual balance in the fund, I am recommending that total assessments increase from a total of \$70,000 to \$77,000. There are approximately 11 property owners assessed, and the formula is based on the linear feet of benefit for the property.

There are 3 parts to this process. First a Resolution of necessity. Second, an Ordinance to proceed with the Improvement. Lastly, an ordinance to assess the property owners. The Finance Department will send out invoices to the property owners for the assessments. For those residents which do not pay up front, the City will assess the lighting on the property tax duplicate for 5 years.

With your approval I would like to place this ordinance on the next available Council agenda.

Please let me know if you have any questions.

Thank You.

A RESOLUTION DECLARING IT NECESSARY TO IMPROVE GEORGE ZEIGER DRIVE BETWEEN CERTAIN TERMINI IN THE CITY OF BEACHWOOD, OHIO, BY PROVIDING STREET LIGHTING; AND DECLARING THIS TO BE AN URGENT MEASURE

WHEREAS, the City has previously authorized and requested The Cleveland Electric Illuminating Company, the City Engineer, and the Finance Director to prepare plans, profiles, specifications and an estimate of cost for the improvement described in Section 1;

NOW, THEREFORE, BE IT RESOLVED by the Council of the City of Beachwood, County of Cuyahoga, and State of Ohio, that:

Section 1. It is declared necessary to improve George Zeiger Drive from Timberlane Road to the southerly terminus of George Zeiger Drive by providing street lighting for a period of five years with seven underground-fed, 100-watt high pressure sodium post top lamps.

Section 2. The specifications and estimate of cost of the improvement now on file in the office of the Clerk of the Council are approved.

Section 3. This Council finds and determines that: (i) the improvement is conducive to the public health, convenience and welfare of this City and the inhabitants thereof and (ii) the lots and lands to be assessed as described in Section 4 hereof are specially benefited by the improvement.

Section 4. The whole cost of the improvement, less 2% of that cost, there being no intersections, shall be assessed in proportion to the benefits which may result from the improvement upon the lots and lands bounding and abutting upon George Zeiger Drive between the termini described in Section 1 hereof.

Section 5. The cost of the improvement shall include all costs of the annual amount charged by The Cleveland Electric Illuminating Company for providing electricity, the cost of specifications and estimates and of printing, serving and publishing notices, resolutions and ordinances, the costs incurred in connection with the preparation, levy and collection of the special assessments, the cost of obtaining legal descriptions and title insurance in connection with the determination of title to the properties to be assessed for the improvement, expenses of legal services, and cost of labor and material, together with all other necessary expenditures. The Finance Director is authorized to advance moneys for the cost of the special assessments from available funds.

Section 6. The Finance Director is authorized and directed to prepare and file in the office of the Clerk of the Council the estimated special assessments of the cost of the improvement described in this Resolution. Those estimated special assessments shall be based upon the estimate of cost of the improvement now on file in the office of the Clerk of the Council and shall be prepared pursuant to the provisions of this Resolution. When the estimated special assessments have been so filed, the Clerk of the Council shall cause notice of the adoption of this Resolution and the filing of the estimated special assessments to be served in the manner provided by law on the owners of all lots and lands to be assessed.

Section 7. The special assessments to be levied shall be paid according to the following payment schedule: in five annual installments, with interest at the rate or rates determined by Council when it passes the assessing ordinance levying those special assessments on the unpaid amount of such special assessments; provided that the owner of any property assessed may pay the special assessment in cash within 30 days after passage of the assessing ordinance.

Section 8. The special assessments to be levied may be levied and collected before the improvement is commenced or completed.

Section 9. Bonds or notes of the City shall not be issued in anticipation of the levy or collection of the special assessments. The remainder of the cost of the improvement after application of the special assessments shall be paid from other available funds of the City.

Section 10. In the event that after the special assessments are certified to the County Fiscal Officer for collection: (i) the annual amount charged by The Cleveland Electric Illuminating Company for providing electricity is increased or (ii) the City is required to advance, from funds other than special assessments collected, moneys to pay the annual amount charged by The Cleveland Electric Illuminating Company for providing electricity, the Clerk of the Council is authorized to calculate and determine the resulting increase in the special assessment against each property, including interest on the moneys advanced, at the rate or rates determined by Council when it passes the assessing ordinance. The increased special assessments shall be in proportion to the original special assessments certified to the County Fiscal Officer. The Clerk of the Council shall cause notice of the resulting increases to be served on the owners of all lots and lands assessed in the manner set forth in Ohio Revised Code Section 727.13 for service of notice of the passage of a resolution of necessity and the filing of the estimated assessments. Any owner of a lot or parcel who objects to the amount of the increased special assessments shall file such objection in writing with the Clerk of the Council within two weeks from the date of completion of the notice required under this section. Such objection shall include the address for mailing of the notice of the meeting of the assessment equalization board hereinafter provided for. An owner who fails to so file an objection shall be deemed to have waived any objection. In the event any objections are received and in the event Council does not provide for another procedure, Council shall appoint an assessment equalization board, consisting of three disinterested freeholders of the City to hear the objections and shall fix the time and place of such hearing. Such notice shall be mailed at least five days before the date of such hearing. The assessment equalization board shall have the powers and duties of an assessment equalization board set forth in Ohio Revised Code Section 727.17. Council may approve or disapprove the report, including any changes recommended by the board in the estimated assessments. In the event Council disapproves the report of the board it shall appoint a new board and shall fix the time and place for the hearing by such board of objections. Such new board shall have the same powers and duties and shall proceed in the same manner as the original board. When Council has approved the report, the Clerk of the Council shall certify the corrected special assessments to the County Fiscal Officer.

Section 11. It is found and determined that all formal actions and deliberations that resulted in formal actions of Council and its committees, relating to the adoption of this Resolution, were in meetings open to the public in compliance with all Beachwood requirements.

RESOLUTION NO. 2026-32

Section 12. This Resolution is declared to be an urgent measure necessary for the public peace, health, safety, or the efficient operation of the City; and for the further reason that the immediate provision for lighting of said public street is necessary for safer and more convenient travel upon said street; wherefore, this Resolution shall be in full force and effect immediately upon its passage and approval by the Mayor.

Attest: I hereby certify this legislation was duly adopted on the 9<sup>th</sup> day of March, 2026, and presented to the Mayor for approval or rejection in accordance with Article III, Section 8 of the Charter on the 10<sup>th</sup> day of March, 2026.

  
\_\_\_\_\_  
Clerk

Approval: I have approved this legislation this 10<sup>th</sup> day of March, 2026 and filed it with the Clerk.

  
\_\_\_\_\_  
Mayor

**CITY OF BEACHWOOD  
FINANCE DEPARTMENT  
INTER-OFFICE COMMUNICATION**

---

**TO:** Mayor Justin Berns  
**FROM:** Larry A. Heiser, Finance Director *LAH*  
**RE:** Street Lighting Blossom Lane and George Zeiger  
**DATE:** February 24, 2026

Every 5 years the City must reassess Blossom Drive residents and George Zeiger Drive Businesses for street lighting. Blossom Lane: the calculation for the 2026 assessments is \$672.28 per resident cost for 5 years. This represents a monthly cost of \$11.20 for each parcel. I have built in a slight escalator of 3% to cover any increases over the next 5-year period. As Council may recall I requested a \$2,000 transfer into the Blossom Fund in 2025 due to the fact that collections for the 2021 assessments did not appear to generate enough revenue to pay the relative invoices for Blossom. If we run a slight surplus moving forward, I would advocate after 4 years to transfer monies back to the General Fund from the Blossom Drive Fund (261).

George Zeiger: Due to the actual balance in the fund, I am recommending that total assessments increase from a total of \$70,000 to \$77,000. There are approximately 11 property owners assessed, and the formula is based on the linear feet of benefit for the property.

There are 3 parts to this process. First a Resolution of necessity. Second, an Ordinance to proceed with the Improvement. Lastly, an ordinance to assess the property owners. The Finance Department will send out invoices to the property owners for the assessments. For those residents which do not pay up front, the City will assess the lighting on the property tax duplicate for 5 years.

With your approval I would like to place this ordinance on the next available Council agenda.

Please let me know if you have any questions.

Thank You.

A RESOLUTION ACCEPTING A QUOTATION FROM DELL MARKETING LP FOR THE PURCHASE OF MICROSOFT OFFICE 365, WAIVING COMPETITIVE BIDDING; AND DECLARING THIS TO BE AN URGENT MEASURE

WHEREAS, Council by Ordinance No. 1986-79 authorized the Mayor to enter into purchase orders with suppliers of products and/or services from a list prepared by the State of Ohio, after the State received competitively bid contracts with such suppliers in accordance with the State laws;

WHEREAS, the IT Manager has recommended the purchase of Microsoft Office 365 as outlined in the Memorandum to the Finance Director dated February 18, 2026;

WHEREAS, Dell Marketing LP pricing is in accordance with the State of Ohio Joint Purchase Master Contract #csp-029109;

WHEREAS, the purchase amount is Forty Thousand Three Hundred Ninety-Three Dollars and Ninety-Two Cents (\$40,393.92) per year for three (3) years for a total amount not to exceed One Hundred Twenty-One Thousand One Hundred Eighty-One Dollars and Seventy-Six Cents (\$121,181.76).

NOW, THEREFORE, BE IT RESOLVED by the Council of the City of Beachwood, County of Cuyahoga, and State of Ohio, that:

Section 1: The Mayor is hereby authorized and directed to purchase Microsoft Office 365 from Dell Marketing, LP in a total amount not to exceed One Hundred Twenty-One Thousand One Hundred Eighty-One Dollars and Seventy-Six Cents (\$121,181.76), and this Council waives competitive bidding. A copy of the quotation is attached hereto and incorporated herein as Exhibit "A".

Section 2: It is found and determined that all formal actions and deliberations of Council and its committees relating to the passage of this legislation that resulted in formal action were in meetings open to the public where required by Chapter 105 of the Codified Ordinances of the City.

Section 3: This Resolution is declared to be an urgent measure necessary for the preservation of the public peace, health, safety, or the efficient operation of the City; and for the further reason that the necessary software critical to City operations be purchased at the earliest time; wherefore, this Resolution shall be in full force and effect immediately upon its passage and approval by the Mayor.

Attest: I hereby certify this legislation was duly adopted on the 9<sup>th</sup> day of March, 2026, and presented to the Mayor for approval or rejection in accordance with Article III, Section 8 of the Charter on the 10<sup>th</sup> day of March, 2026.

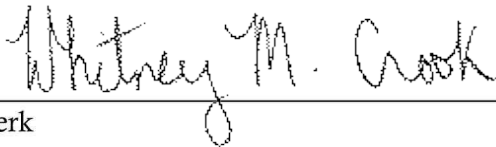
  
Clerk

Approval: I have approved this legislation this 10<sup>th</sup> day of March, 2026 and filed it with the Clerk.

  
Mayor

# Memorandum

---

**To:** Larry Heiser, Finance Director  
**From:** Craig Kaufman, IT Manager  
**Subject:** Microsoft Office 365  
**Date:** February 18, 2026

Approved 2/20/2026



---

I am requesting authorization to renew our Microsoft Office 365 subscription for a new three-year term at a total cost of \$121,181.76. This renewal ensures continued access to Office 365 and Exchange services, along with automatic updates, security patches, and the latest software versions throughout the contract period. Although Exchange is hosted by Microsoft, we will continue to maintain our email backups through our existing cloud service.





This renewal is available through Dell Marketing LP under the State of Ohio Joint Purchase Master Contract #CSP029109. Pricing is based on the number of licensed users; therefore, costs may increase if additional employees require email or Office services. However, the per-user rate is locked for the full three years.

Dell holds the state contract for Microsoft Office, and it is my recommendation that we proceed with the renewal through Dell Marketing LP at a cost of \$40,393.92 per year for three years. I have attached the quote and state term pricing.

I am requesting that this item be added to the next council agenda for consideration.

Cc: Carol Morrison



True-Up Steps	
	<b>Online Service Reservation Review</b>
	<b>System/User Inventory</b>
	<b>Review Meeting</b>
	<b>Issue a Purchase Order</b>
	<b>True-Up Submission</b>

\* Microsoft provides the MAP Toolkit to help you gather data and insights on deployed software instances and versions. For reconciliation of all licenses within your environment for a nominal fee. For more information on this service, please contact your account manager.

**ing Your True-Up**

Microsoft Enterprise 6			
City of Beachwood			
Date Updated	Enrollment #	Start Date	End Date
2/5/2026	5052158	3/8/2023	3/31/2026

			Responsible Party
--	--	--	-------------------

If any Online Services have been self-provisioned by agreement administrators in the past year, a review is necessary to determine if those subscriptions need to be carried into future years or if they are transitions from on-premises licenses. Dell & City of Beachwood

---

Count your applicable on-premises systems/applications to determine if any usage has changed since the previous renewal or True-Up.\* City of Beachwood

---

Review the inventory data gathered and the total number of needed licenses on the True-Up. Highlight any optimization or cost savings to finalize True-Up counts. Dell & City of Beachwood

---

Create a Purchase Order addressed to Microsoft Corporation as the payee and provide a copy to Dell for the total listed on the "True-Up" tab. City of Beachwood

---

Dell to review and process the final True-Up 30 to 60 days before the anniversary date to fulfill the True-Up compliance requirements. Dell

---

For more information on this free tool, [click here](#). Additionally, Dell has trusted partners who perform custom software asset management email your Dell Technologies Software Account Team.

Due Date
3/7/2026

	Completion Date
ood	1/24/2026
	1/24/2026
ood	2/7/2026
	3/6/2026
	3/7/2026

ngagements to aid in the inventory and



Part Number	Description
<b>Enterprise Products and Online Services</b>	
U4S-00002	O365 G1 GCC Sub Per User
AAA-11894	O365 G3 GCC Sub Per User
<b>Additional Online Services</b>	
1O5-00001	Power Automate Premium GCC Sub Per User
NYH-00001	Teams AC with Dial Out US/CA GCC Sub Add-on
<b>Additional On-Premises Products</b>	
<b>Other Licenses / Services</b>	

*True-Up pricing for perpetual licenses is a one time charge for the full license cost plus a prorated amount for Software A. Most Online Services can be reduced at the agreement anniversary date. Per the Microsoft Enterprise Agreement language.*

**Year 2 True-Up**

Microsoft Enterprise 6			
City of Beachwood			
Date Updated	Enrollment #	Start Date	End Date
2/5/2026	5052158	3/8/2023	3/31/2026

Country of Use	Originating Qty	Pending Reservations	Total Qty	Currently Running Qty	Qty to True-Up
United States	155	0	155		0
United States	90	0	90		0
United States	1	0	1		0
United States	245	0	245		0

insurance coverage through the end of the agreement.  
 age, all reductions must be submitted **no later** than 30 days before the annual agreement anniversary date.





Part Number	Description
<b>Online Service Reservations</b>	

*Online Service Reservations are self-provisioned subscriptions added via the Microsoft VLSC portal throughout the agreement year. Microsoft charges for the number of full months between the start date of the subscription thru the agreement end date.*

**License Reservations**

Microsoft Enterprise 6		
City of Beachwood		
<b>Date Updated</b>	<b>Enrollment #</b>	<b>Start Date</b>
2/5/2026	5052158	3/8/2023

Usage Country	Reservation #	Usage Date	Qty Reserved

:

End Date	Due Date
3/31/2026	3/7/2026

# Months	Price Per Month	Extended Total
0		\$0.00
0		\$0.00
<b>Year 2 PreTax Reservation Total</b>		<b>\$0.00</b>



<b>Microsoft</b>
City of Beachwood, OH
<b>Date Updated</b> 2/5/2026

Part Number	Description
<b>Enterprise Products and Online Services</b>	
U4S-00002	O365 G1 GCC Sub Per User
AAA-11894	O365 G3 GCC Sub Per User
<b>Additional Online Services</b>	
1O5-00001	Power Automate Premium GCC Sub Per User
NYH-00001	Teams AC with Dial Out US/CA GCC Sub Add-on
<b>Other Licenses / Services</b>	

Contract Code: C000001302001

*Most Online Services can be reduced at the agreement anniversary date. Per the Microsoft Enterprise Agreement language*

**S IS EA Renewal**

Enterprise 6			
Enrollment #	Start Date	End Date	Months Remaining
TBD	4/1/2026	3/31/2029	12

Country of Use	Originating Qty	Pending Reservations	Total Qty	Yearly Price
United States	155	0	155	\$107.76
United States	90	0	95	\$247.68
United States	1	0	1	\$161.52
United States	245	0	245	\$0.00
				<b>Year 1 Total</b>
				<b>Year 2 Total</b>
				<b>Year 3 Total</b>
				<b>Grand Total</b>

age, all reductions must be submitted **no later** than 30 days before the annual agreement anniversary date.

Extended Total	
	\$16,702.80
	\$23,529.60
	\$161.52
	\$0.00
	<b>\$40,393.92</b>
	<b>\$40,393.92</b>
	<b>\$40,393.92</b>
	<b>\$121,181.76</b>





Invoice Summary

Microsoft Enterprise 6				
City of Beachwood				
Date Updated	Enrollment #	Start Date	End Date	Due Date
2/5/2026	5052158	3/8/2023	3/31/2026	3/7/2026

State	Description	Pretax Total	PO#
Draft	Year 3 Online Service Reservations Total	\$0.00	
Draft	Year 3 True-Up Total	\$0.00	
Final	Renewal - Year 1 Annual Invoice	\$40,393.92	
<b>Total Expected Invoice Amounts</b>		<b>\$40,393.92</b>	

Contract Code: C000001302001

**\*\*All Purchase Orders are to be addressed to Dell\*\***



View Public Catalogs

Keywords ⓘ

U4S-00002

Search

Reset

Supplier

Commodities

Item tag

State Contract Number

Contracting Entity

MBDD Status

Filters Keywords: U4S-00002 x

Image	Commodity	Product Code	Supplier	Name	State Contract Number	UOM	Validity End Date	Item tag	Price	State Contract Number	Manufacturer	Summary	Index Number	MBDD Status	Manufacturer P
	Software	CSP29109-1070	DELL MARKETING LP	O365 G1 GCC Sub Per User	<a href="#">CSP029109 - Enterprise Microsoft LSP Amendment #1</a>	AMT	6/30/2030		108.870	CSP029109	Microsoft	O365 G1 GCC Sub Per User			U4S-00002

View Public Catalogs

Keywords ⓘ

AAA-11894

Search

Reset

Supplier

Commodities

Item tag

State Contract Number

Contracting Entity

MBDD Status

Filters Keywords: AAA-11894 x

Image	Commodity	Product Code	Supplier	Name	State Contract Number	UOM	Validity End Date	Item tag	Price	State Contract Number	Manufacturer	Summary	Index Number	MBDD Status	Manufacturer P
	Software	CSP29109-1158	DELL MARKETING LP	O365 G3 GCC Sub Per User	<a href="#">CSP029109 - Enterprise Microsoft LSP Amendment #1</a>	AMT	6/30/2030		250.390	CSP029109	Microsoft	O365 G3 GCC Sub Per User			AAA-11894

View Public Catalogs

Keywords

105-00001 Search Reset

Supplier Commodities Item tag State Contract Number Contracting Entity

MBDD Status

Filters Keywords: 105-00001

Image	Commodity	Product Code	Supplier	Name	State Contract Number	UOM	Validity End Date	Item tag	Price	State Contract Number	Manufacturer	Summary	Index Number	MBDD Status	Manufacturer
	Software	CSP29109-1399	DELL MARKETING LP	Power Automate Premium GCC Sub Per User	<a href="#">CSP029109 - Enterprise Microsoft LSP Amendment #1</a>	AMT	6/30/2030		163.300	CSP029109	Microsoft	Power Automate Premium GCC Sub Per User			105-00001

A RESOLUTION APPROVING RECOMMENDED AMENDMENTS TO THE CITY OF BEACHWOOD CIVIL SERVICE RULES; AND DECLARING THIS TO BE AN URGENT MEASURE.

WHEREAS, Article VI, Section 3(3) of the City Charter provides that all rules promulgated by the Civil Service Commission are subject to approval by City Council;

WHEREAS, the Civil Service Commission has reviewed and formally adopted amendments to the City of Beachwood Civil Service Rules;

WHEREAS, the Civil Service Commission has submitted its adopted amendments to City Council and has recommended Council’s approval of the same.

NOW, THEREFORE, BE IT RESOLVED BY THE Council of the City of Beachwood, County of Cuyahoga, and State of Ohio, that:

Section 1. City Council hereby approves the amendments to the City of Beachwood Civil Service Rules as adopted by the Civil Service Commission and as set forth in **Exhibit “A”**, which is attached hereto and incorporated herein by reference.

Section 2: It is found and determined that all formal actions and deliberations of Council and its committees, relating to the passage of this legislation that resulted in formal action were in meetings open to the public where required by Chapter 105, Codified Ordinances of the City.

Section 3: This Resolution is declared to be an urgent measure necessary for the public peace, health, safety, or the efficient operation of the City; and for the further reason that the approved amendments to the Civil Service Rules must be implemented without delay to ensure the effective administration of City classified civil service for the Police and Fire Departments and the need for immediate hiring of personnel; wherefore this Resolution shall be in full force and effect immediately upon its passage and approval by the Mayor.

Attest: I hereby certify this legislation was duly adopted on the 9<sup>th</sup> day of March, 2026, and presented to the Mayor for approval or rejection in accordance with Article III, Section 8 of the Charter on the 10<sup>th</sup> day of March, 2026.

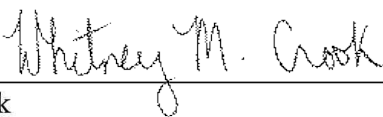
  
Clerk

Approval: I have approved this legislation this 10<sup>th</sup> day of March, 2026 and filed it with the Clerk.

  
Mayor

**BEACHWOOD CLERK OF COUNCIL  
INTER-OFFICE MEMORANDUM**

**TO:** City Council

**FR:** Whitney M. Crook, MMC, CPM, Clerk of Council/Civil Service Coordinator

**DT:** February 12, 2026

**RE:** Summary of Proposed Amendments to the Civil Service Commission Rules

---

**Purpose:**

This memorandum is intended to inform City Council of the proposed amendments to the Civil Service Commission Rules as approved by the Civil Service Commission, the process undertaken to develop those amendments, and the key changes requiring Council approval pursuant to the City Charter.

---

The Civil Service Commission Rules govern the administration of examinations, appointments, promotions, and other personnel matters for classified service positions (Police and Fire Department personnel) within the City. Pursuant to Article VI, Section 3(3) of the City Charter, all rules promulgated by the Civil Service Commission are subject to approval by City Council before becoming effective.

The Rules amendments before Council reflect a comprehensive review of the existing Rules to ensure clarity, consistency, and alignment with operational needs, legal requirements, and best practices in civil service administration. Council approval is required to formally adopt these amendments and authorize their implementation.

---

**Process and Review**

The review and amendment process was collaborative and deliberate. Initial meetings were held with the Fire Chief, Police Chief and City Administration to identify operational considerations, departmental needs, and areas where clarification or modernization of the rules would be beneficial. These discussions included topics related to examinations, promotions, scoring practices, and minimum qualifications.

Following these discussions, the Civil Service Commission conducted several meetings to review, discuss, and refine the proposed amendments. The Commission carefully evaluated recommended changes, considered feedback from City administration, the Law Director, and department leadership, and made revisions where appropriate to ensure fairness, consistency, and compliance with applicable law. After thorough discussion and refinement, the Commission formally adopted the proposed amendments.

---

## Summary of Proposed Changes

Significant elements of the proposed amendments include the following:

- Establishment of defined minimum qualifications for Police Department candidates
- Elimination of additional seniority points for promotional candidates in both the Police and Fire Departments
- Transition from weighted percentage-based scoring to a points-based scoring system for all Entry Level and Lateral Transfer Fire and Police civil service examinations
- Clarification and refinement of examination administration, scoring, and ranking procedures
- Updates to appointment, promotion, and eligibility list provisions
- Administrative and procedural revisions intended to improve transparency, consistency, and ease of application
- Modernization of language, revisions for internal consistency of language, and formatting for clarity and usability

Collectively, these changes are intended to promote fairness in the examination and promotional process, standardize scoring methodologies, and ensure the Civil Service Commission Rules clearly reflect current practices and expectations.

Please feel free to contact me should you have any questions or require additional information regarding the proposed amendments. I would be happy to provide any further details.

Respectfully submitted,

Whitney Crook  
Civil Service Coordinator



Rules of the Civil Service Commission

City of Beachwood

Cuyahoga County, Ohio

~~Adopted~~ Revisions adopted by Ordinance No. ~~2023-80~~ 2026-

RULES OF THE CIVIL SERVICE COMMISSION  
OF THE  
CITY OF BEACHWOOD, OHIO

PREAMBLE

Pursuant to the power and authority granted by the Charter of the City of Beachwood, the Civil Service Commission hereby adopts the following amended rules governing the Civil Service Commission of the City of Beachwood effective ~~August 15, 2023~~, 2026.

A. ORGANIZATION AND STAFF

Section 1. Establishment of Commission

A Civil Service Commission is established by the Charter. A member of any commission or board established by the Charter or by the Council conformable to Article VI, Section 1, therein shall be deemed an officer of this City within the meaning of the Charter. The Civil Service Commission members are therefore deemed officers of this City. (Beachwood Charter - Article VI, Section 1)

Section 2. Civil Service Commission; Composition, Vacancy and Removal

In accordance with the Charter, the Civil Service Commission shall consist of three residents of the City not holding any other City office to be appointed by the Mayor to serve staggered terms of six (6) years, with one member's term expiring every two (2) years on January 1, following a regular Municipal election. A vacancy occurring during the term of any member of the Commission shall be filled for the unexpired term in the manner authorized for an original appointment. Removal of a member of the Civil Service Commission is governed by Article VI, Section 4 of the Charter. (Beachwood Charter - Article VI, Section 3, 1. and Section 4).

Section 3. Mayor as Appointing Authority

The Mayor of the City of Beachwood shall, pursuant to the City Charter, is the appointing authority for the City.

Section 4. Civil Service Divisions; Unclassified and Classified Service

The Civil Service of the City is divided into the unclassified and classified service.

- (a) ~~(A)~~ The unclassified service shall include all elected, appointed and employed persons of the City except those included in the classified service.

~~(B)~~

The classified service shall consist of all Police Officers and Fire ~~\_\_\_\_\_~~ Fighters who are appointed and \ or promoted by competitive civil ~~\_\_\_\_\_~~ Service examination, excluding the Chief and any Deputy Chief of ~~\_\_\_\_\_~~ ~~The the~~ Police Department and the Chief and any Assistant Chief of ~~\_\_\_\_\_~~ the Fire Department, ~~to be known as the safety forces.~~ ~~\_\_\_\_\_~~ Council, by ordinance, shall create each rank in the ~~safety forces~~ ~~\_\_\_\_\_~~ Police and Fire Departments and the number of persons to serve in each rank. Such ordinance

- (b) ~~\_\_\_\_\_~~ shall be known as the table of organization.

~~\_\_\_\_\_~~ (Beachwood Charter

~~\_\_\_\_\_~~ Article VI, Section 3, 1(B))

Section 45. Responsibilities of Commission; Rules

The Civil Service Commission shall make all necessary rules for its procedure, the appointment and promotion of persons in the classified service, independent of the general law of the State of Ohio where permitted to do so, and such other rules as the Commission determines to be necessary. Before any such rules or amendments thereof shall become effective, they shall be approved by City Council and published in writing and publicly posted on the bulletin board in City Hall and shall become effective thirty (30) days after approval by City Council, unless some later date is specified therein.

The Commission shall provide rules for the procedure of the Commission; for standardization and classification of positions; for competitive examinations for qualifications in meeting reasonable and lawful requirements as to age, physical condition

and moral character; and for such investigations and rules as may be necessary and proper for the implementation of the Civil Service system for employment, appointment and promotion within the City.

The Commission may amend these Rules or adopt new Rules by a majority vote of the Commission members at any of its meetings, subject only to the approval of City Council. A copy of all proposed amendments to these rules shall be sent to the Chief of each affected department for recommendations prior to passage. A copy of these Rules and a copy of all subsequent Rules or Amendments shall be sent as soon as practicable after adoption to each affected department of the City, and a copy shall be maintained in the office of the Commission for public inspection.

The Commission shall report its proceedings to the Mayor or Council upon request.

Section 56. Officers; Chairperson

At its first meeting in each calendar year, the Commission shall designate one of its members as chairperson. In case of vacancy before the expiration of the term for which such chairperson is designated, the office shall be filled in a like manner.

The Chairperson shall preside at all meetings of the Commission and shall act as spokesperson for the Commission. The Chairperson shall designate one of the Commissioners to act as Chairperson Pro Tempore during the absence of the Chairperson. If no such designation has been made, the two Commissioners present shall agree who shall act as Chairperson Pro Tempore.

Section 67. Secretary

In accordance with Article III, Section 4 of the Charter, Council shall appoint a Clerk who shall be the Clerk of Council and Secretary of the Planning Commission, Civil Service Commission and of all boards and commissions established by Council. The Clerk shall keep the records of Council and of the boards and commissions of which the Clerk is secretary. The Clerk shall authenticate all records, documents and instruments of the City required by law and perform other duties required by Council. Council may also appoint

Assistant Clerks of Council to assist the Clerk and to act in the Clerk's absence. (Beachwood Charter - Article III, Section 4)

In addition to acting as Secretary of the Commission, the Clerk shall perform all other functions necessary for the proper implementation of these Rules and the City Charter and ordinances relating to Civil Service and the provisions of the State law not in conflict therewith and such additional duties as may be assigned from time to time by the Commission.

Section 78. Quorum

Two members of the Commission shall constitute a quorum for the transaction of business, and the concurrence of two members shall be required for any action.

Section 89. Official Signatures

The Chairperson of the Commission, or ~~his or her~~ the Chairperson's designee, is authorized to sign all papers and other documents for and on behalf of the Commission. In the absence of the Chairperson, the remaining two members of the Commission shall have such power.

Section 910. Official Records

The Commission shall keep in the form of minutes, a record of the official actions of the Commission with regard to:

- (a) All appointments and promotions,
- (b) Lists of all examinations administered with their dates,
- (c) Results of all requests for re-grading,
- (d) Classifications of positions and changes in classifications,
- (e) Appointments of special examiners,
- (f) Decisions in all hearings,
- (g) Other official business transacted by the Commission.

Copies of eligibility lists, applications, and correspondence shall also be kept by the Secretary and retained in accordance with municipal record retention requirements.

Section ~~10~~11. Official Roster

A file, to be known as the "Official Roster" shall be kept by the City. This file shall contain the name of every person in the classified service. This file shall show the following with respect to each employee:

- (a) Name of the employee,
- (b) Address of the employee,
- (c) Title of the office or employment,
- (d) Date and character of each appointment and each Subsequent change in status, and
- (e) Date of examination and listing, grade received and rank of the eligible list.

Section ~~11~~12. Meetings; Rules of Order; Communications

Meetings of the Commission shall be subject to call of the chairperson or any two members of the Commission. Meetings shall be held in the City Hall as often as may be necessary for the prompt transaction of all business.

All meetings of the Commission shall be open and public, and all persons shall be permitted to attend any meetings of the Commission, except as otherwise provided herein.

The Commission may hold executive sessions to consider the employment of an employee or to hear complaints, unless such officer or employee requests a public hearing. The Commission also may, at its discretion, exclude witnesses and others.

Except as otherwise provided herein, Robert's Rules of Order - Newly Revised, shall guide the Commission in its proceedings.

Communications and requests to the Commission, insofar as practicable, shall be in writing. The substance of each request and the action of the Commission thereon shall be noted in the minutes.

B. CLASSIFICATION

Section 1. Classification; Investigation; Changes

The Civil Service Commission may from time to time, upon its own motion, make investigation of all positions in the service and propose changes in classification whenever the facts are considered to warrant such action, subject to the requirements of the City's collective bargaining agreements, and the provisions of the City's ordinances governing employment.

## C. APPLICATIONS AND APPLICANTS

### Section 1. General Requirements; Residency and Citizenship

To the extent permitted by law, the Commission may determine and state in the announcement of each examination whether applicants shall be restricted to residents of the City of Beachwood or other City, County, State, or the United States. The overall policy governing the decision in each case shall be that of securing an adequate number of well-qualified applicants.

Unless otherwise limited by law, every applicant for admission to examination for a position in the classified service in the City of Beachwood must be a citizen of the United States, or have legally declared ~~his or her~~ [the applicant's](#) intention of becoming a citizen of the United States and be authorized to work in the United States. Upon filing an application, applicants must present to the City proof of citizenship or proof that the applicant has legally declared ~~his or her~~ [the applicant's](#) intention of becoming a citizen of the United States and authorization to work in the United States.

### Section 2. Filing of Applications; Fee; Attachments

Applicants must fill out, and sign the blank form of application furnished by the Commission. The applicant must file a completed application form giving fully, truthfully, and accurately all information required. An applicant's notarized signature certifying as to the truth and completeness of the information contained in the application shall be required on each application.

The Secretary may refuse to accept any incomplete application that is not fully completed or that does not contain all required information or attachments as set forth in the examination notice. All applications, when completed and filed, become the property of the Commission and thereafter may not be returned to the applicant. The Commission may impose a reasonable fee for the processing of applications and may provide for waiving such fee based on evidence of inability to pay as determined by the Commission.

Applications must be received at the office of the Commission not later than 4:00 p.m. on the last day for filing as posted on the official bulletin board of the Commission. Applications will be subject to amendment not later than 4:00 p.m. of the last day for filing. Burden of proof of meeting application and filing requirements shall lie with the applicant. In case of any dispute as to the time of filing, the Secretary's official time recorded on the application shall be conclusive.

The time for filing applications may be extended or reopened by the Commission and as the needs of the service require, provided notice is immediately posted on the bulletin board in City Hall and by such other manner provided at [Article D](#), Section 3, herein for examination notices as is designated by the Commission.

All applicants for original entry level appointment as a firefighter/paramedic or police officer must attach a copy of ~~his/her~~[the applicant's](#) valid state drivers' license and a copy of ~~his/her~~[the applicant's](#) high school diploma or G.E.D. certificate to the application at the time of filing. All applicants for original entry—level appointment as a firefighter/paramedic must also attach a copy of ~~his/her~~[the applicant's](#) valid state ~~Paramedic~~[paramedic](#) certification card or proof of current enrollment in a ~~Paramedic Program~~[paramedic program](#) to the application at the time of filing.

For purposes of these Civil Service Rules, a "Lateral Transfer" is a person who is currently employed as a sworn law enforcement officer under a state or federal law by another law enforcement agency.

Lateral Transfer applications may be accepted at any time by the Secretary of the Commission. These applications will be reviewed and applicants will be notified when examinations are conducted. This notification can be done via email or other written correspondence. ~~Lateral Transfer applicant requirements are~~[shall be](#) in accordance with ~~section~~[Article C\(4\), Sections 5 and 6](#) of these Civil Service Rules. [Lateral Transfer applicants](#)

shall have held Ohio Peace Officer Training Academy (“OPOTA”) certification for a minimum of one (1) year at the time of application and must be currently employed fulltime by a local, state or federal law enforcement agency or be in a laid off status from such agency.

Section 3. Initial Application Requirements; ~~Moral Character Certificates;~~ for Entry-Level Fire Fighter/EMT-Paramedic Position, EMT-Paramedic Certification; Ohio Driver’s License

~~Applicants for original entry level appointments must furnish satisfactory proof of being a person of good moral character, of correct and orderly deportment, and of temperate and industrious habits by certificates of not less than four reputable citizens of their state of residence, not holding any public office or position in any political party organization, each certifying that he or she has been personally acquainted with the applicant for at least two years and believes the applicant to be of good moral character, of temperate and industrious habits and in all respects qualified for the contemplated service, and that each such citizen is willing that such certificate shall be made public. Additional certificates of character may be required in any case at the discretion of the Commission. All statements submitted by an applicant as to his\her character and fitness shall be attached to the application at the time of filing and may be subject to investigation by the Commission.~~

~~In order to apply for entry level testing to become a Beachwood firefighter\paramedic, the applicant must provide proof that he\she holds a current EMT-Paramedic certification.~~ To apply for original entry-level appointment as a Beachwood Fire Fighter/Paramedic, the applicant must provide proof that the applicant holds a current EMT-Paramedic certification or proof of enrollment in a State of Ohio approved Paramedic Certification program Any applicant without such certification or proof of enrollment shall not be permitted to apply for the position. Certification must be obtained within 12 months of hiring.

~~Any non-resident holding a current EMT-Paramedic certification from another state may be permitted to present a current EMT-Paramedic certification from the State of Ohio within three months of eligibility.~~

If an applicant is offered employment with the City and is a non-resident holding a valid out of state driver’s license the applicant will be permitted to present a current driver’s license from the State of Ohio within sixty days of appointment.

#### Section 4. Physical and Mental Requirements; Age

To be eligible for open competitive appointment as a ~~police officer or firefighter\paramedic~~ Police Officer or Fire Fighter/Paramedic, the applicant shall be physically and mentally capable of performing the duties of the position. Upon the determination of the Commission, a physical ~~agility~~ ability test must be passed either: 1) prior to sitting for the open competitive examination or 2) prior to the time that an applicant's name appears on an eligibility list.

\_\_\_\_\_ For original entry-level appointment as a ~~police officer~~ Police Officer, a psychological interview, testing and/or evaluation may be required after a conditional offer of employment is made and prior to ~~the interview with the Civil Service Commission. a final appointment.~~

\_\_\_\_\_ For original entry-level appointment as a ~~firefighter/paramedic~~ Fire Fighter/Paramedic, a psychological interview, testing and/or evaluation may be required after a conditional entry-level employment offer is made and prior to appointment. An applicant for police officer and firefighter/paramedic must pass a physical examination after a conditional entry-level employment offer is made.

\_\_\_\_\_ Any applicant for Police Officer and Fire Fighter/Paramedic must pass a physical examination after a condition offer of entry-level appointment is made and prior to final appointment.

To the extent permitted by law and reasonably related to the requirements of the position, the job description for any particular position may include further requirements regarding physical and mental condition.

To file an application, ~~an~~ for an original entry-level appointment as a Fire Fighter/Paramedic, the applicant ~~for an open competitive appointment as a firefighter\paramedic~~ must have attained ~~his\her~~ the applicant's eighteenth birthday and shall not have obtained ~~his\her~~ the applicant's thirty-fifth birthday ~~and~~.

\_\_\_\_\_ To file an ~~applicant~~ application for an ~~open competitive~~ original entry-level appointment as a ~~police officer~~ Police Officer, the applicant must have attained ~~his\her~~ the applicant's twenty-first birthday and shall not have ~~obtained his\her~~ attained the applicant's thirty-fifth birthday. ~~On the date of~~

\_\_\_\_\_ To file an application for an open competitive appointment, ~~an~~ as a Lateral Transfer Police Officer, the applicant ~~for the position of firefighter\paramedic to be eligible~~ shall not

have attained ~~his\her thirty fifth~~the applicant's forty-second birthday ~~and an applicant for the position of police officer to be eligible shall not have attained his\her thirty fifth birthday.~~ Such age requirements shall be governed by the general law of the State of Ohio. ~~On the date of a lateral application, the applicant for the positions of firefighter/paramedic and police officer shall not have attained his/her fortieth birthday.~~

Section 5.— Physical and Medical Examinations

Physical and medical examinations by a physician designated by the City shall be required after a conditional employment offer is made to an applicant for original entry level appointment. If a candidate for a ~~lateral transfer~~Lateral Transfer has completed employment examinations within one (1) year of the City's conditional offer of employment, the Commission may accept the examinations in lieu of requiring new examinations. Such physical and medical examination requirements shall be governed by ~~the general law of the State of~~Ohio Police & Fire Pension Fund standards.

Section 6. ~~Non-Acceptance~~Minimum Qualifications for Entry-Level and Lateral Transfer Police Officer Positions

To ensure candidates meet the professional, ethical, and legal standards required for service in the City of Beachwood Police Department, applicants for Entry-Level and Lateral Transfer Police Officer positions shall meet the following minimum qualifications. Applications failing to meet any of these criteria shall be rejected by the Civil Service Commission Secretary and shall not proceed to examination or interview.

(a) Age and Legal Status

- o Original Entry-Level Police Officer: Applicant must be at least 21 years of age and not older than 35 years at the time of application.
- o Lateral Transfer Police Officer: Applicant must be at least 21 years of age and not older than 42 years at the time of application.
- o Applicant must be a United States citizen or legally authorized to work in the United States.

(b) Employment History

- o Applicant must not have been terminated from previous employment for cause, including but not limited to dishonesty, excessive absenteeism, or conduct unbecoming of a law enforcement officer.

(c) Criminal History

- o Applicant must not have been convicted of any felony.
- o Applicant must not have been convicted of any misdemeanor involving moral turpitude, violence, domestic violence, or controlled substances.

- Convictions that have been expunged or sealed may be evaluated in accordance with applicable law.

(d) Drug and Alcohol History

- Applicant must not have past or current substance abuse that would impair the applicant's ability to perform police duties safely and effectively.

(e) Licenses and Certifications

- Applicant must possess a valid driver's license and must not have a record of repeated serious traffic violations that would prevent the safe operation of a police vehicle.
- Lateral transfer applicants must hold a valid Ohio Peace Officer Training Academy (OPOTA) certification.

The Civil Service Commission Secretary is authorized to reject any application that does not meet the minimum qualifications outlined in this section. Falsification or omission of information on the employment application will result in disqualification. Applicants whose applications are rejected shall be notified in writing

Section 7. Rejection of ~~Applicants~~Applications; Withholding or Removal of Names from Eligibility List

In addition to the reasons in Section 6 above for rejection of applications by the Commission Secretary, the following are reasons for the Commission to reject an application for a. ~~lacks~~ position in the classified service or to withhold or remove an applicant from an eligible list:

(a) Lacks any of the minimum qualifications set forth in the examination notice;

(b. ~~does~~) Does not meet the medical or physical requirements of the position for which appointment is sought;

(c. ~~has~~) Has made false statement(s) in ~~his/her~~the applicant's application with regard to any material fact or has practiced or attempted to practice any deception or fraud in ~~his/her~~the application or examination, in securing ~~his/her~~the applicant's eligibility, or appointment or promotion;

(d. ~~was~~) Was previously in the ~~Classified~~classified City Civil Service in the same or any other type of employment and was removed for cause or did not resign in good standing;

(e. ~~has~~) Has used or attempted to use any political pressure to further ~~his/her~~the applicant's eligibility for appointment or promotion;

(f. ~~is~~) Is addicted to the use of intoxicating liquor or narcotics or habit-forming drugs or addicted to gambling;

(g. ~~had~~) Had been convicted of a felony or a misdemeanor involving moral turpitude, violence, domestic violence, or controlled substances within the last seven years, or admitted to criminal activity determined to have a direct relationship to the position for which application is made, ~~except that conviction of a felony shall automatically disqualify an applicant for any law enforcement officer position. Such rejection.~~ Such rejection, withholding, or removal shall take into consideration the seriousness of the offense, the age of the offense, and the age of the applicant at the time of its occurrence. Conviction of a felony shall automatically disqualify an applicant for any law enforcement officer position;

(h. ~~has~~) Has been dismissed from previous employment for delinquency or misconduct;

(i) ~~refuses~~ Refuses to furnish all information required to complete the application;

(j. ~~is~~) Is knowingly a member of any subversive ~~organizations,~~ organization that espouses illegal means to subvert an established and legally-constituted system or institution or who is knowingly a member of any organization which, to ~~his\her~~ the applicant's knowledge, now advocates the overthrow of the government of the United States or of this State by force or violence or other unlawful means, or who now advocates the support of a foreign government against the United States in the event of hostilities;

(k. ~~refuses~~) Refuses to execute any oath or affirmation, as prescribed by law;

(l. ~~fails~~) Fails to be present for fingerprinting;

(m. ~~has~~) Has assisted in preparing, conducting or scoring any examination for which the candidate applies or who has in any other manner secured confidential information concerning such examination which might give ~~him\her~~ the applicant an unfair advantage over other applicants on the examination;

(n. ~~fails~~) Fails to be present for or fails to pass the physical and ~~and~~/or medical examination;

(o. ~~)~~ Submits a written request ~~from the applicant~~ that ~~his\her~~the applicant's name be removed from the eligibility list;

(p. ~~failure~~) Failure to appear for a scheduled interview or to schedule an interview or other required appointment within the time period stated in the notice to do so, unless said applicant is on the promotional list and shall have specifically waived ~~his\her~~the applicant's right to a promotional appointment;

(q. ~~in~~) In any case where the Commission finds that an applicant is or has in any manner become disqualified for the position for which ~~he\she~~the applicant is listed, in accordance with these Rules;

(r. ~~failure~~) Failure to notify the Secretary of changes in address;

(s. ~~appointment~~) Appointment to a permanent position through certification from an eligible list for an equivalent or higher rank;

~~\_\_\_\_\_~~ (t. ~~in~~) In the case of promotional lists, upon separation from City employment, other than layoff from City service;

(u. ~~failure~~) Failure to pass the polygraph examination or voice stress truth verification test for positions ~~in the Department~~for which such examination and tests are required;

(v. ~~failure~~) Failure to pass a pre-employment interview or background investigation, the purpose of which is to determine if the applicant had the background and ability to function as an effective ~~police officer or firefighter-paramedic~~Police Officer or Fire Fighter/Paramedic;

(w. ~~failure~~) Failure to notify the Commission of receiving other employment or no longer being interested in seeking employment with the City for any other reason; \_\_\_\_\_ or

(x. ~~has~~) Has applied to the City for a Lateral Transfer position in the last two (2) years.

#### D. EXAMINATIONS

## Section 1. Types of Examination

Examinations shall be of three kinds:

- (a) ~~Original Entry-Level~~ Open ~~competitive~~ Competitive (entrance) examination
- ~~(b)~~ (a) Lateral Examination;
- (b) Lateral Transfer Examination; and
- (c) Promotional ~~examination~~ Examination.

~~Both the~~ The Original Entry-Level Open Competitive ~~and~~ Lateral Transfer, and Promotional Examinations may be collectively referred to herein as “original entry level appointment.” Examinations shall be written, oral and ~~and/or written~~ an assessment center format and of such a character and relate to such matters as will, in the opinion of the Commission, fairly test the relative fitness of the persons examined to discharge the duties of the positions to which they seek appointment. All applicants for ~~open competitive appointment~~ Original Entry-Level Open Competitive and Lateral Transfer appointments shall receive at least a minimum passing score of 70% on the written examination, as determined by the Commission. Based upon the ranking of scores on the written or other initial portion of the examination process, sufficient applicants in the opinion of the Commission to meet anticipated requirements of the Mayor shall then be required to continue with the remaining portions of the examination process, including the oral interview, prior to being ranked on the final eligibility list. Such applicants may be required to complete psychological testing and evaluation after a conditional offer of appointment has been made to the applicant.

Promotional examination applicants receiving at least a minimum passing score of 70% on the written examination may be required to complete psychological testing and evaluation.

## Section 2. Separate Examinations and Eligibility ~~List~~ Lists for Police and ~~Firefighter~~ Fire Fighter/Paramedics

Separate examinations shall be given and separate eligibility lists maintained by the Civil Service Commission for ~~original entry level appointments to and promotions~~ all classified civil service positions in the Fire and Police Departments. No person may be transferred from one list to the other. ~~Original entry level appointments~~ Appointments and promotions in said departments shall be only from the separate eligibility lists maintained for each of said departments. Transfers of personnel from one department to the other are hereby prohibited.

### Section 3. Examinations; Public Notice

Whenever the Mayor requests that the Commission certify names from an eligibility list for a vacant position for an ~~entry-level~~Original Entry-Level position in the ~~safety forces~~Police or Fire Departments or for a Promotional position in ~~the safety forces~~those Departments above the lowest grade, the Commission shall conduct an examination to create an eligibility list, if no such list exists for such position. ~~For entry-level examination~~For an Original Entry-Level Examination or a Lateral Transfer Examination, an eligibility list will be valid for one (1) year and no more than (2) years unless the Commission determines that the list is no longer valid after less than one (1) year due to lack of adequate, well-qualified applicants. For ~~positions~~Promotional Examinations above the lowest grade, ~~an eligible~~ list shall be valid for not less than one (1) year nor more than two (2) years. At any time after the first year but before the end of the second year, the Commission may determine that the list is no longer valid. All examinations will be conducted within sixty (60) days of the Mayor's request for certification of names from an eligibility list when one is required, or as soon thereafter as is practical. The Commission may conduct an ~~open-competitive examination~~Original Entry-Level Open Competitive Examination, a ~~lateral-examination~~Lateral Transfer Examination, or both. Each type of examination will have its own separate and independent eligibility list.

Examinations shall be held under the direction of the Commission at such places as the Commission deems advisable. Public notice of the time and place of every examination shall be given at least 30 days prior to the date thereof on the bulletin board in City Hall. In addition, copies of said notices shall also be posted in the department for which the test is to be given.

~~Notice of all open-competitive examinations shall be published in one or more newspapers of general circulation in the area from which applicants will be permitted to apply, as indicated by the Commission in its announcement. Examination notices may also be given in other~~ Examination notices may be given in any written, printed or electronic form as designated by the Commission. Such notices shall also contain any other information relating to the scope of the examination,(s), the weights, if any, to be attached to the ~~respective subjects~~,various components of the examination(s), the qualifications of the applicants, and such other information as the Commission may deem proper.

#### Section 4. Development of Examination

Examinations shall be of such character and relate to such matters as will fairly test the relative fitness of the persons examined to discharge the duties of the positions to which they seek appointment. All examinations shall be based on objective and approved examination methods. Examination shall be conducted under the supervision of the Commission, and when necessary and advisable, Special Examiners may be designated by the Commission to assist in the conduct of the same.

#### Section 5. Safeguarding of Examinations; Candidate Identification Number

At the time of filing ~~his/her~~ a candidate's application, each candidate shall be assigned an identification number by the Secretary of the Commission. All examination papers submitted by applicants shall contain their number only, and any ~~paper record,~~ written or electronic, bearing the name of an applicant or other identification mark that was caused by the applicant to be so identified or marked shall be rejected and the applicant shall be notified of disqualification.

#### Section 6. Marking or ~~-Score~~; College ~~Credit; Interviews~~and ~~Military Credits~~; Ranking on Eligibility List

Prior to the administration of an examination the Commission shall determine (i) the overall passing score; (ii) what percentage of the passing score shall be determined by each ~~element~~component or part of the examination process; and (iii) any minimum passing score for each ~~section~~component or part of the examination. ~~No~~ process. For examinations other than Promotional Examinations: (i) no credit shall be given for residency. ~~Not;~~ (ii) not more than one ~~percent (1%)~~point of the final score shall be added to the final grade of any person with a two (2)~~-~~-year college degree from an accredited college or university or not more than two ~~percent (2%)~~points of the final score be added to the final grade of any person with a four (4)~~-~~-year college degree from an accredited college or university, provided that the applicant has obtained at least the minimum passing grade on the written or other initial examination and further provided that copies of the ~~applicants'~~applicant's college transcripts showing the degree are attached to the application at the time of filing the same. ~~No;~~ and (iii) no applicant shall receive more than two ~~percent (2%)~~points total added to their scores for college degrees.

The Commission may also provide that no more than three ~~percent (3%)~~points to be added to the scores of applicants who have completed at least one hundred and eighty (180) days of active duty U.S. military service, have received an honorable discharge, and have

obtained at least the minimum passing score on the written or other initial examination, and further that the applicant has provided discharge documents or other proof of honorable U.S. military service.

No applicant can receive more than five ~~percent (5%)~~ points total added to their scores for ~~College/Military/Certification~~ college and/or military credit. No college or military credit will be added for ~~lateral~~ Lateral Transfer examinations.

The Commission may contract with others to assist in the examination or evaluation of applicants.

All marking of scores shall be in accordance with the ~~weights~~ points and/or weight given for the respective ~~subjects~~ components/parts of the examination and credit points established by the Commission and any outside ~~Examiner~~ examiner engaged by the Commission. Each ~~portion~~ component/part of the examination process must be passed or completed prior to proceeding to the next ~~portion~~ component/part.

The Commission shall have the absolute discretion to limit the number of interviews of applicants, based upon their ranking scores, and depending upon the number of open positions to be filled. Therefore, interviews may be conducted when and if they are deemed required by the Commission.

Upon completion of ~~interviews~~ the examination process as approved by the Commission, the Commission will ~~incorporate~~ add the various scores and credit points as determined by it to have been used for ~~Departmental Evaluations, Examinations, Assessments, Civil Service Interviews (in the case of entry level and lateral transfers) and College/Military/Certification,~~ the particular examination process, or as otherwise provided in these Rules, and place ~~said~~ the applicants on the eligibility list in their order of ranking based upon ~~the~~ their final scores.

## Section 7. Inspection of Papers; Applicant's Right to Object

Any applicant for an examination who objects to the examination shall file a written notice of objection with the Secretary of the Commission as soon as reasonably possible, but not later than ten (10) calendar days prior to the examination.

~~Any applicant who objects to the conduct of the written or any other portioncomponent/part of the examination shall file a written objection or protest with the Secretary of the Commission as soon as reasonably possible after the written or other initial examination component/part, but not later than five (5) calendar days after the administration of the written or other initial-portioncomponent/part of the examination. Any applicant for an examination who objects to a question or the scoring on the written or other initial portion of the examination shall file a written objection or protest within five (5) days after the results of the written or other initial examination are posted.~~

Any applicant for an examination who objects to a question or the scoring on the written or other component/part of the examination shall file a written objection or protest within five (5) calendar days after the results of the written or other initial examination are posted. Applicants shall be notified by electronic mail of the posting of scores.

Any applicant for an examination who objects to or the final ranking after the examination process is completed shall file an objection with the Secretary of the Commission as soon as reasonably possible, but not later than five (5) calendar days after the final ranking is posted.

Any applicant shall have the right, at any time within the period of five (5) calendar days after the results of the written or other initial examination are posted, to review ~~his\her~~the applicant's own answer sheets and inform ~~himself\herself~~the applicant as to the markings given ~~him\her~~the applicant on each subject or question and to submit in writing for the Commission's consideration, any objections or protest the applicant may wish to make concerning a question or the scores given the applicant.

No objection or protest concerning an examination, not submitted in writing, shall be considered unless it relates to the conduct of examiners, the securing of unlawful assistance by a competitor or such other circumstances in connection with an examination as would call for an investigation on the part of the Commission, and which would require that the information submitted be given in confidence.

An applicant who exercises the right to inspect the examination papers shall not be permitted to take an examination again for the same classification within a six--month

period following the inspection, unless an alternate form of examination is given. ~~Inspection~~ At the sole discretion of the Commission, inspection of standardized tests prepared by experts outside of the City ~~shall~~may not be permitted, where such inspection would tend to reduce the validity of current and future test results.

The Commission will consider the objections and take such action as the circumstances warrant, and its findings shall be final.

Any clerical error may be corrected by the Secretary upon discovery at any time during the life of the eligibility list, but no such correction shall affect an appointment from a certification made prior to the correction.

#### E. CORRESPONDENCE

##### Section 1: Notification of Grade and Placement on Eligibility List

All applicants shall be notified in writing by the Secretary of the Commission at the last electronic mail and U.S. Mail address, as shown by the records of the Commission, of ~~his\her~~the applicant's grade on the written or other ~~initial~~component/part of the examination; and again when ~~a candidate~~an applicant is to be placed on the eligibility list.

##### Section 2: Notification of Certification to Mayor from Eligibility List

Each eligible candidate shall be notified in writing by the Secretary of the Commission when certified to the Mayor for appointment. Such notice shall include that a background check may be performed and that ~~he or she~~the candidate may be required to appear for an interview with the ~~appointing authority~~Mayor. Such notice shall be sent by electronic mail and U.S. regular mail to the last address of the eligible candidate as shown by the records of the Commission.

##### Section 3: Reports from Appointing Authority

The Mayor shall make a written report to the Commission indicating whether any of the persons certified in the pool failed to appear for a scheduled interview, whether a candidate was or candidates were selected for appointment from the pool and given a conditional job offer pending the results of the required physical examination, and whether any of the candidates declined or waived appointment.

##### Section 4: Notification of Pass Over and Results of Physical Examination upon Conditional Job Offer

The Secretary of the Commission shall notify in writing any candidate not chosen for appointment. This notification shall be done upon verification from the Police Chief or the Fire Chief that another candidate has verbally accepted appointment.

The Secretary of the Commission shall notify the Mayor in writing upon receipt of notification of the results of the physical examination of a candidate who has been given a conditional job offer.

#### Section 5: Notification of Address Change

Every ~~applicant~~candidate and each person, whose name appears on an eligibility list, shall file with the Commission a written notice of any change in ~~his\her~~the candidate's electronic mail and U.S. Mail address. Such notice shall state ~~his\her~~the candidate's name, the eligibility list on which ~~his\her~~the candidate's name appears, ~~his\her~~the candidate's new address,(es), and ~~his\her~~the candidate's last address(es) as registered with the Commission. Failure to do so may result in such candidate's name being removed from the list.

#### Section 6: Canvass of Eligibility Lists

Whenever ~~he or she~~the Secretary of the Commission believes the needs of the ~~service~~classified Civil Service require, the Secretary ~~of the Commission~~ shall ascertain through written correspondence or telephone authorization the availability for employment of persons whose names appear on an eligibility list.

### F. ELIGIBILITY LIST

#### Section 1. Development of List

Sufficient ~~names~~candidates in the opinion of the Commission to meet the anticipated requirements of the Mayor to fill a position shall be required to pass the psychological tests, if required to be administered, ~~and~~in order to proceed with the interview process.

Duly qualified applicants shall be placed on the eligibility list and ranked in the order of their final ~~score after proportionate~~ scores ~~on~~after the ~~written or other initial examination, interview with the Civil Service Commission, Departmental Evaluations, Examinations, Assessments, Civil Service Interviews (in the case of entry level and lateral transfers) and College/Military/Certification~~ scores are totaled and points are added for seniority credits (if applicable), and as otherwise provided in these Rules.

Whenever the Mayor determines to fill a vacancy for a position in the ~~safety forces,~~ Police and Fire Departments, the Mayor shall request that the Commission certify names from the appropriate eligibility list.  
(Beachwood Charter, Article VI, Section 3, 3(E) (1)).

Section 2. Priority

When two or more eligible applicants have received the same score, the person first-filing an application, or, if the examination ~~be~~is for promotion, the person with the longest seniority in the department, shall have priority.

### Section 3. Duration

The date of certification shall be clearly shown on all eligibility lists. All eligibility lists for promotional positions ~~above the lowest grade~~ shall be valid for not less than one (1) nor more than two (2) years. At any time after the first year, but before the end of the second year, the Commission may declare that the list is no longer valid. ~~For entry-level~~ Original Entry-Level positions and Lateral Transfer positions, an eligibility list will be valid for one (1) year and no more than two (2) years unless the Commission determines that the list is no longer valid after less than one (1) year due to the lack of adequate, well-qualified applicants.

### Section 4. Disqualification

If, at any time, the Commission has reason to believe that any person, upon the eligibility list, has in any manner become disqualified for the position sought as indicated at ~~C. Section 6.~~ Article C, Sections 6 and 7, herein, a notice to such person and an opportunity to be heard, in the person's own behalf, shall be given. Upon failure to satisfy the Commission that the person is duly qualified, said name shall be removed from such eligibility list. ~~If a person upon any list has reached the maximum age limit specified for the position for which the person is eligible at the time of certification, such name shall be removed from the list and the person shall be notified of such action and such name shall not be certified to the Mayor for appointment.~~

## G. CERTIFICATION AND APPOINTMENT

### Section 1. Certification and Examination Criteria

(a) Examinations of applicants for the eligibility list for ~~open competitive~~ Original Entry-Level Open Competitive appointment for Police ~~Patrol~~ Officer shall be based upon the following factors:

~~50%~~ Maximum 100 points on WRITTEN EXAMINATION

~~20%~~ Maximum 10 points on ORAL INTERVIEW WITH CIVIL SERVICE COMMISSION

~~30% DEPARTMENTAL (ASSIGNED BY CHIEF OF THE~~ Maximum 10 points on POLICE DEPARTMENT) — ASSESSMENT

(b) Examinations of applicants for the eligibility list for ~~open competitive~~ Original Entry-Level Open Competitive appointment ~~Firefighter~~ for Fire Fighter/Paramedic shall be based upon the following factors:

~~50%~~ Maximum 100 points on WRITTEN EXAMINATION

Maximum 20% points on ORAL INTERVIEW WITH CIVIL SERVICE COMMISSION  
~~30% DEPARTMENTAL (ASSIGNED BY CHIEF OF THE~~Maximum 30 points on FIRE DEPARTMENT) ASSESSMENT

(c)– Examinations of applicants for the eligibility list for ~~lateral~~Lateral Transfer appointments in the Police Department shall be based on the following factors:

~~60% WRITTEN OR OTHER EXAMINATION~~  
~~10% ORAL INTERVIEW WITH CIVIL SERVICE COMMISSION~~  
~~30% DEPARTMENTAL (ASSIGNED BY CHIEF OF THE~~  
Maximum 100 points on POLICE DEPARTMENT) ASSESSMENT

~~The Civil Service Commission will rank applicants for the eligibility list for Entry Level Police Officer, Entry Level Firefighter/Paramedic, Lateral Transfer Police Officer and Lateral Transfer Firefighter/Paramedic to be shared with the Fire Chief and Police Chief(d) (d) Examination~~

(i) For Fire Captain Promotions

40% WRITTEN EXAMINATION  
60% ASSESSMENT CENTER

(ii) For Fire Lieutenant Promotions

60% WRITTEN EXAMINATION  
40% ASSESSMENT CENTER

(iii) For Police Lieutenant Promotions

40% WRITTEN EXAMINATION  
60% ASSESSMENT CENTER

(iv) For Police Sergeant Promotions

60% WRITTEN EXAMINATION  
40% ASSESSMENT CENTER

~~The Civil Service Commission will rank applicants for the eligibility list for~~

~~promotion which will be shared with the Fire Chief and Police Chief.~~

~~—The Civil Service Commission consideration for ranking of eligibility for promotion may be based upon past job performance, attendance records, leadership qualities, and quality of work—~~

## Section 2. Certification and Selection by Mayor; Probationary Period

- (a) ~~—~~ Upon receipt of notice from the Mayor that a vacancy exists for an original entry level appointment, the Commission shall certify to such appointing authority the names of the ten (10) persons ranked highest on the eligibility list for that position. The Mayor shall appoint one (1) of the ten (10) to fill the office.
- (b) ~~—~~ If there is more than one (1) vacancy to be filled for an original entry level appointment, the number of names to be certified shall be determined in the following manner:
- (i) ~~—~~ The Commission shall certify ten (10) names from the eligibility list for one (1) position to be filled plus two (2) names for each additional position to be filled. (i.e. ~~2~~, two positions open - certify ~~12~~twelve names, ~~3~~three positions open – certify ~~14~~fourteen names).
- (ii) ~~—~~ The Mayor shall consider each ~~person~~candidate so certified for an ~~original entry level~~Original Entry-Level appointment. When ~~there are~~ both an ~~open competitive~~Original Entry-Level eligibility list and a ~~lateral~~Lateral Transfer eligibility list ~~valid~~are in effect at the same time, the Mayor may appoint a candidate from either list. ~~select potential hires from only one eligibility list at a time. In no circumstance shall candidates from multiple lists be considered simultaneously.~~
- (iii) ~~—~~ If an eligibility list contains less than ten (10) names, the Mayor may accept the lesser number and appoint from such list, or may require a new list of ten (10) names for each position to be filled.

The ~~person~~candidate selected for appointment shall be duly notified by the Mayor, and if the person so selected shall fail to respond within four (4) calendar days to the notice of appointment sent by electronic mail or by registered or certified mail to ~~his\her post office~~the appointee's address(es) as registered with the Commission, said person shall be stricken from the eligibility list. If, however, it shall be made to appear to the satisfaction of the Commission within thirty (30) days after giving such notice that the person was unavoidably and without fault prevented from accepting said appointment, the name may be restored to its proper position on the eligibility list.

Certification for promotional appointments shall be governed by Article K herein.

~~All original entry level and promotional~~

Original Entry-Level and Promotional appointments in the classified Civil Service shall be for a probationary period of one (1) year, ~~and from the person so appointed is~~date of appointment but with the exception of Original Entry-Level Police Officers who shall be for a probationary period of one (1) year after successful completion of their field training. All probationary appointees are subject to removal from ~~such position~~their positions by the Mayor during such one (1)-year period without appeal to the Civil Service Commission. No appointment shall be deemed final until the appointee has satisfactorily served the probationary period.

#### H. POLITICAL ACTIVITY

Persons holding positions in the classified service shall not be discriminated against in any way because of their political opinions or political affiliations, or because of the exercise of their right to vote as they please and to express their opinions on political subjects. However, they shall take no active part in political management or political campaigns; and they ~~may not~~shall neither act as officers of election committees nor be officers in any political organization.

Nothing in this ~~section~~article prohibits an officer or employee from serving as a precinct election official under section 3501.22 of the Revised Code, but an officer or employee who serves as a precinct election official must use vacation leave to so serve.

## I. PAPERS: PROPERTY OF THE COMMISSION

All original papers, applications, examination papers, answer sheets, questions, certificates, etc., are the property of the Commission and must be filed in the office of the Commission and kept for not less than three years, except the examination papers of those failing to pass, which may be destroyed after ninety days.

## J. TEMPORARY AND EMERGENCY APPOINTMENTS

### Section 1. Temporary Appointments

Upon receipt of request for certification for a position for which no appropriate eligibility list is available, the Commission shall notify the Mayor that nomination for temporary appointment may be made to fill such position until an eligibility list can be created, or for a period not to exceed ninety days.

### Section 2. Emergency Appointments

Emergency appointments may be made by the Mayor when, in the judgment of the Mayor, the good of the service, the health, safety or welfare of the public, and\or the necessities of the City's operation make it necessary to do so. Written notice, however, must be given forthwith to the Commission, together with the reasons for making such emergency appointments, and such reasons must be sufficient and satisfactory to the Commission. The emergency appointment shall not be effective for a period longer than ninety days.

## K. PROMOTIONS

### Section 1. Examination for Promotions

Whenever the Mayor requests that the Commission certify names from an eligibility list for a vacant position in the ~~safety forces~~ Departments of Police and Fire above the lowest grade, the Commission shall, if no list exists, conduct an examination consistent with ~~Section~~ Article D of these Rules, to create an eligibility list, which shall be valid for not less than one (1) nor more than two (2) years. At any time after the first year, but before the end of the second year, the Commission may determine that the list is no longer valid.

Applicants for promotion shall be examined on such practical and theoretical questions as in the judgment of the Commission pertain to the office or rank to which

promotion is sought, upon the State Laws, the City Ordinances, Rules and Regulations pertaining to the duties of said office or rank, and upon such other subjects or tests which the Commission may prescribe.

## Section 2. Eligibility List for Promotions

Before conducting an examination for a promotional position, the Commission shall ascertain whether there are at least two (2) persons who are eligible and willing to take a competitive examination to fill such vacancy.

- (a) If at least two (2) such persons take and pass the examination for a promotional position, the Mayor shall appoint one (1) of the persons from such list.
- (b) If only one (1) person passes the examination for a promotional position and/or the Mayor objects to one (1) name on the eligibility list, or if no person passes the examination, the Commission shall conduct another examination permitting all persons in the next lower rank below the rank to be filled and eligible persons in the second next lower rank below the rank to be filled, to compete.
- (c) To be eligible for a promotional examination for the rank next above Patrol Officer in the Police Department or next above the rank of Fire Fighter in the Fire Department, a person must have served at least thirty-six (36) months continuously in the lower rank, including probationary time. To be eligible for a promotional examination for other higher ranks, a person must have continuously served at least one (1) year in the next lower rank. In the event of circumstances not covered by these Rules, the Commission shall determine the required eligibility which shall require not less than one (1) year of continuous service in a lower rank.
- (d) Promotional applicants may be required to complete psychological testing [and evaluation.](#)

~~\_\_\_\_\_and evaluation.~~

Section 3: ~~Additional Credit for Promotional Examinations~~

~~\_\_\_\_\_ (1) Seniority in the same department shall be added to the examination grade, in accordance with the provisions of the general law of the State of Ohio, but no additional credit for seniority or any other reason shall be added to an examination grade unless the applicant achieves at least a minimum passing score on the written part of the examination.~~

~~\_\_\_\_\_ (2) Credit for Seniority shall be determined as of the date of the written examination.~~

~~\_\_\_\_\_ (3) The Commission shall establish a rule for the addition of "chief's points," permitting the Chiefs of the Departments of Police and Fire to add performance and efficiency points as the Commission shall permit to the final grade of a person in such Chief's Department.~~

Section 4: Certification for Appointment for Promotions

After the promotional examination has been graded, and subject to Section 2 (b) above or upon the Mayor's request if an eligibility list exists, the Commission shall certify to the Mayor the names and grades of the five (5) persons ranking highest or such lesser number as appears on the eligibility list. The Mayor shall promote one (1) of such persons within thirty (30) days after certification, provided at least two (2) persons remain on the eligibility list. The Mayor may appoint the remaining person if only one (1) name remains on the list, or may request that the Commission conduct another examination subject to Section 2 (b) above. ~~The Mayor shall consider each person so certified in the order of ranking. Every person shall be considered three times to fill a vacancy.~~ If any person is not appointed after being ~~considered~~certified for consideration for appointment to a vacant position three (3) times, such person shall be removed from the eligibility list. ~~The first year of such promotion shall be probationary, as provided above. It is the intention of the Civil Service Commission to evaluate applicants on the basis of their ability to perform the duties required for the rank applied for.~~

Section 54. Notice of Examination

Notice of all promotional examinations shall be posted by the Secretary in a conspicuous place in the City Hall and upon the collective bargaining unit's bulletin board in the applicable Department not less than thirty (30) days before the date fixed for the examination. Such notice shall give the date and the character of the examination, and shall indicate the grade or rank of persons eligible to compete. Applicants for promotion shall file their applications as the Commission has prescribed in its notice.

L. WAIVER OF RULES

~~Section 1. Waiver of Rules~~

In specific cases where, in the sole discretion of the Commission, it is in the interest of the public service, any of the rules hereby adopted may be waived by the unanimous vote of all three members of the Commission; provided, however, that such waiver shall not be inconsistent with the provisions of the Charter and ordinances of the City of Beachwood or where applicable, the laws of the State of Ohio. Such action, together with the reasons therefor, shall be entered in the minutes of the Commission. In the interest of justice to all concerned and to promote the welfare of the Civil Service in the City of Beachwood, Ohio a wide degree of liberality of construction and interpretation of these Rules and Regulations in any and all circumstances and situations shall be the policy to be adopted and followed by the Commission in its administration of the Civil Service system.

I, WHITNEY M CROOK, Clerk of Council & Secretary to the Civil Service Commission, do hereby certify that the foregoing is a true and correct copy of the Rules of the Civil Service Commission of the City of Beachwood, Ohio (as revised ~~August 14, 2023~~ August 15, 2023).

Date: ~~August 14, 2023~~ August 15, 2023

WHITNEY M. CROOK

Clerk of Council & Civil Service Commission Secretary  
City of Beachwood, Ohio



Rules of the Civil Service Commission

City of Beachwood

Cuyahoga County, Ohio

Revisions adopted by Ordinance No. 2026-\_\_

RULES OF THE CIVIL SERVICE COMMISSION  
OF THE  
CITY OF BEACHWOOD, OHIO

PREAMBLE

Pursuant to the power and authority granted by the Charter of the City of Beachwood, the Civil Service Commission hereby adopts the following amended rules governing the Civil Service Commission of the City of Beachwood effective \_\_\_\_\_, 2026.

A. ORGANIZATION AND STAFF

Section 1. Establishment of Commission

A Civil Service Commission is established by the Charter. A member of any commission or board established by the Charter or by the Council conformable to Article VI, Section 1, therein shall be deemed an officer of this City within the meaning of the Charter. The Civil Service Commission members are therefore deemed officers of this City. (Beachwood Charter - Article VI, Section 1)

Section 2. Civil Service Commission; Composition, Vacancy and Removal

In accordance with the Charter, the Civil Service Commission shall consist of three residents of the City not holding any other City office to be appointed by the Mayor to serve staggered terms of six (6) years, with one member's term expiring every two (2) years on January 1, following a regular Municipal election. A vacancy occurring during the term of any member of the Commission shall be filled for the unexpired term in the manner authorized for an original appointment. Removal of a member of the Civil Service Commission is governed by Article VI, Section 4 of the Charter. (Beachwood Charter - Article VI, Section 3, 1. and Section 4).

Section 3. Mayor as Appointing Authority

The Mayor of the City of Beachwood shall, pursuant to the City Charter, is the appointing authority for the City.

Section 4. Civil Service Divisions; Unclassified and Classified Service

The Civil Service of the City is divided into the unclassified and classified service.

- (a) The unclassified service shall include all elected, appointed and employed persons of the City except those included in the classified service.
- (b) The classified service shall consist of all Police Officers and Fire Fighters who are appointed and/or promoted by competitive civil Service examination, excluding the Chief and any Deputy Chief of the Police Department and the Chief and any Assistant Chief of the Fire Department. Council, by ordinance, shall create each rank in the Police and Fire Departments and the number of persons to serve in each rank. Such ordinance shall be known as the table of organization.  
(Beachwood Charter Article VI, Section 3, 1(B))

Section 5. Responsibilities of Commission; Rules

The Civil Service Commission shall make all necessary rules for its procedure, the appointment and promotion of persons in the classified service, independent of the general law of the State of Ohio where permitted to do so, and such other rules as the Commission determines to be necessary. Before any such rules or amendments thereof shall become effective, they shall be approved by City Council and published in writing and publicly posted on the bulletin board in City Hall and shall become effective thirty (30) days after approval by City Council, unless some later date is specified therein.

The Commission shall provide rules for the procedure of the Commission; for standardization and classification of positions; for competitive examinations for qualifications in meeting reasonable and lawful requirements as to age, physical condition and moral character; and for such investigations and rules as may be necessary and proper for the implementation of the Civil Service system for employment, appointment and promotion within the City.

The Commission may amend these Rules or adopt new Rules by a majority vote of the Commission members at any of its meetings, subject only to the approval of City Council. A copy of all proposed amendments to these rules shall be sent to the Chief of each affected department for recommendations prior to passage. A copy of these Rules and a copy of all subsequent Rules or Amendments shall be sent as soon as practicable after adoption to each affected department of the City, and a copy shall be maintained in the office of the Commission for public inspection.

The Commission shall report its proceedings to the Mayor or Council upon request.

Section 6. Officers; Chairperson

At its first meeting in each calendar year, the Commission shall designate one of its members as chairperson. In case of vacancy before the expiration of the term for which such chairperson is designated, the office shall be filled in a like manner.

The Chairperson shall preside at all meetings of the Commission and shall act as spokesperson for the Commission. The Chairperson shall designate one of the Commissioners to act as Chairperson Pro Tempore during the absence of the Chairperson. If no such designation has been made, the two Commissioners present shall agree who shall act as Chairperson Pro Tempore.

Section 7. Secretary

In accordance with Article III, Section 4 of the Charter, Council shall appoint a Clerk who shall be the Clerk of Council and Secretary of the Planning Commission, Civil Service Commission and of all boards and commissions established by Council. The Clerk shall keep the records of Council and of the boards and commissions of which the Clerk is secretary. The Clerk shall authenticate all records, documents and instruments of the City required by law and perform other duties required by Council. Council may also appoint Assistant Clerks of Council to assist the Clerk and to act in the Clerk's absence. (Beachwood Charter - Article III, Section 4)

In addition to acting as Secretary of the Commission, the Clerk shall perform all other functions necessary for the proper implementation of these Rules and the City Charter and ordinances relating to Civil Service and the provisions of the State law not in conflict therewith and such additional duties as may be assigned from time to time by the Commission.

Section 8. Quorum

Two members of the Commission shall constitute a quorum for the transaction of business, and the concurrence of two members shall be required for any action.

Section 9. Official Signatures

The Chairperson of the Commission, or the Chairperson's designee, is authorized to sign all papers and other documents for and on behalf of the Commission. In the absence of the Chairperson, the remaining two members of the Commission shall have such power.

Section 10. Official Records

The Commission shall keep in the form of minutes, a record of the official actions of the Commission with regard to:

- (a) All appointments and promotions,
- (b) Lists of all examinations administered with their dates,
- (c) Results of all requests for re-grading,
- (d) Classifications of positions and changes in classifications,
- (e) Appointments of special examiners,
- (f) Decisions in all hearings,
- (g) Other official business transacted by the Commission.

Copies of eligibility lists, applications, and correspondence shall also be kept by the Secretary and retained in accordance with municipal record retention requirements.

#### Section 11. Official Roster

A file, to be known as the "Official Roster" shall be kept by the City. This file shall contain the name of every person in the classified service. This file shall show the following with respect to each employee:

- (a) Name of the employee,
- (b) Address of the employee,
- (c) Title of the office or employment,
- (d) Date and character of each appointment and each Subsequent change in status, and
- (e) Date of examination and listing, grade received and rank of the eligible list.

#### Section 12. Meetings; Rules of Order; Communications

Meetings of the Commission shall be subject to call of the chairperson or any two members of the Commission. Meetings shall be held in the City Hall as often as may be necessary for the prompt transaction of all business.

All meetings of the Commission shall be open and public, and all persons shall be permitted to attend any meetings of the Commission, except as otherwise provided herein.

The Commission may hold executive sessions to consider the employment of an employee or to hear complaints, unless such officer or employee requests a public hearing. The Commission also may, at its discretion, exclude witnesses and others.

Except as otherwise provided herein, Robert's Rules of Order - Newly Revised, shall guide the Commission in its proceedings.

Communications and requests to the Commission, insofar as practicable, shall be in writing. The substance of each request and the action of the Commission thereon shall be noted in the minutes.

## B. CLASSIFICATION

### Section 1. Classification; Investigation; Changes

The Civil Service Commission may from time to time, upon its own motion, make investigation of all positions in the service and propose changes in classification whenever the facts are considered to warrant such action, subject to the requirements of the City's collective bargaining agreements, and the provisions of the City's ordinances governing employment.

## C. APPLICATIONS AND APPLICANTS

### Section 1. General Requirements; Residency and Citizenship

To the extent permitted by law, the Commission may determine and state in the announcement of each examination whether applicants shall be restricted to residents of the City of Beachwood or other City, County, State, or the United States. The overall policy governing the decision in each case shall be that of securing an adequate number of well-qualified applicants.

Unless otherwise limited by law, every applicant for admission to examination for a position in the classified service in the City of Beachwood must be a citizen of the United States or have legally declared the applicant's intention of becoming a citizen of the United States and be authorized to work in the United States. Upon filing an application, applicants must present to the City proof of citizenship or proof that the applicant has legally declared the applicant's intention of becoming a citizen of the United States and authorization to work in the United States.

### Section 2. Filing of Applications; Fee; Attachments

Applicants must fill out and sign the blank form of application furnished by the Commission. The applicant must file a completed application form giving fully, truthfully, and accurately all information required. An applicant's notarized signature certifying as to the truth and completeness of the information contained in the application shall be required on each application.

The Secretary may refuse to accept any incomplete application that is not fully completed or that does not contain all required information or attachments as set forth in the examination notice. All applications, when completed and filed, become the property of the Commission and thereafter may not be returned to the applicant. The Commission may impose a reasonable fee for the processing of applications and may provide for waiving such fee based on evidence of inability to pay as determined by the Commission.

Applications must be received at the office of the Commission not later than 4:00 p.m. on the last day for filing as posted on the official bulletin board of the Commission. Applications will be subject to amendment not later than 4:00 p.m. of the last day for filing. Burden of proof of meeting application and filing requirements shall lie with the applicant. In case of any dispute as to the time of filing, the Secretary's official time recorded on the application shall be conclusive.

The time for filing applications may be extended or reopened by the Commission and as the needs of the service require, provided notice is immediately posted on the bulletin board in City Hall and by such other manner provided at Article D. Section 3, herein for examination notices as is designated by the Commission.

All applicants for original entry level appointment as a firefighter/paramedic or police officer must attach a copy of the applicant's valid state drivers' license and a copy of the applicant's high school diploma or G.E.D. certificate to the application at the time of filing. All applicants for original entry-level appointment as a firefighter/paramedic must also attach a copy of the applicant's valid state paramedic certification card or proof of current enrollment in a paramedic program to the application at the time of filing.

For purposes of these Civil Service Rules, a "Lateral Transfer" is a person who is currently employed as a sworn law enforcement officer under a state or federal law by another law enforcement agency.

Lateral Transfer applications may be accepted at any time by the Secretary of the Commission. These applications will be reviewed and applicants will be notified when examinations are conducted. This notification can be done via email or other written correspondence. Lateral Transfer applicant requirements shall be in accordance with Article C. Sections 5 and 6 of these Civil Service Rules. Lateral Transfer applicants shall have held Ohio Peace Officer Training Academy ("OPOTA") certification for a minimum of one (1) year at the time of application and must be currently employed fulltime by a local, state or federal law enforcement agency or be in a laid off status from such agency.

Section 3. Initial Application Requirements for Entry-Level Fire Fighter/EMT-Paramedic Position, EMT-Paramedic Certification; Ohio Driver's License

To apply for original entry-level appointment as a Beachwood Fire Fighter/Paramedic, the applicant must provide proof that the applicant holds a current EMT-Paramedic certification or proof of enrollment in a State of Ohio approved Paramedic Certification program Any applicant without such certification or proof of enrollment shall not be permitted to apply for the position. Certification must be obtained within 12 months of hiring.

If an applicant is offered employment with the City and is a non-resident holding a valid out of state driver's license the applicant will be permitted to present a current driver's license from the State of Ohio within sixty days of appointment.

Section 4. Physical and Mental Requirements; Age

To be eligible for open competitive appointment as a Police Officer or Fire Fighter/Paramedic, the applicant shall be physically and mentally capable of performing the duties of the position. Upon the determination of the Commission, a physical ability test must be passed either: 1) prior to sitting for the open competitive examination or 2) prior to the time that an applicant's name appears on an eligibility list.

For original entry-level appointment as a Police Officer, a psychological interview, testing and/or evaluation may be required after a conditional offer of employment is made and prior to a final appointment.

For original entry-level appointment as a Fire Fighter/Paramedic, a psychological interview, testing and/or evaluation may be required after a conditional entry-level employment offer is made and prior to appointment. An applicant for police officer and firefighter/paramedic must pass a physical examination after a conditional entry-level employment offer is made.

Any applicant for Police Officer and Fire Fighter/Paramedic must pass a physical examination after a condition offer of entry-level appointment is made and prior to final appointment.

To the extent permitted by law and reasonably related to the requirements of the position, the job description for any particular position may include further requirements regarding physical and mental condition.

To file an application for an original entry-level appointment as a Fire Fighter/Paramedic, the applicant must have attained the applicant's eighteenth birthday and shall not have obtained the applicant's thirty-fifth birthday.

To file an application for an original entry-level appointment as a Police Officer, the applicant must have attained the applicant's twenty-first birthday and shall not have attained the applicant's thirty-fifth birthday.

To file an application for an open competitive appointment as a Lateral Transfer Police Officer, the applicant shall not have attained the applicant's forty-second birthday.

#### Section 5. Physical and Medical Examinations

Physical and medical examinations by a physician designated by the City shall be required after a conditional employment offer is made to an applicant for original entry level appointment. If a candidate for a Lateral Transfer has completed employment examinations within one (1) year of the City's conditional offer of employment, the Commission may accept the examinations in lieu of requiring new examinations. Such physical and medical examination requirements shall be governed by Ohio Police & Fire Pension Fund standards.

#### Section 6. Minimum Qualifications for Entry-Level and Lateral Transfer Police Officer Positions

To ensure candidates meet the professional, ethical, and legal standards required for service in the City of Beachwood Police Department, applicants for Entry-Level and Lateral Transfer Police Officer positions shall meet the following minimum qualifications. Applications failing to meet any of these criteria shall be rejected by the Civil Service Commission Secretary and shall not proceed to examination or interview.

- (a) Age and Legal Status
  - Original Entry-Level Police Officer: Applicant must be at least 21 years of age and not older than 35 years at the time of application.
  - Lateral Transfer Police Officer: Applicant must be at least 21 years of age and not older than 42 years at the time of application.
  - Applicant must be a United States citizen or legally authorized to work in the United States.
- (b) Employment History
  - Applicant must not have been terminated from previous employment for cause, including but not limited to dishonesty, excessive absenteeism, or conduct unbecoming of a law enforcement officer.

- (c) Criminal History
  - Applicant must not have been convicted of any felony.
  - Applicant must not have been convicted of any misdemeanor involving moral turpitude, violence, domestic violence, or controlled substances.
  - Convictions that have been expunged or sealed may be evaluated in accordance with applicable law.
- (d) Drug and Alcohol History
  - Applicant must not have past or current substance abuse that would impair the applicant's ability to perform police duties safely and effectively.
- (e) Licenses and Certifications
  - Applicant must possess a valid driver's license and must not have a record of repeated serious traffic violations that would prevent the safe operation of a police vehicle.
  - Lateral transfer applicants must hold a valid Ohio Peace Officer Training Academy (OPOTA) certification.

The Civil Service Commission Secretary is authorized to reject any application that does not meet the minimum qualifications outlined in this section. Falsification or omission of information on the employment application will result in disqualification. Applicants whose applications are rejected shall be notified in writing

Section 7. Rejection of Applications; Withholding or Removal of Names from Eligibility List

In addition to the reasons in Section 6 above for rejection of applications by the Commission Secretary, the following are reasons for the Commission to reject an application for a position in the classified service or to withhold or remove an applicant from an eligible list:

- (a) Lacks any of the minimum qualifications set forth in the examination notice;
- (b) Does not meet the medical or physical requirements of the position for which appointment is sought;
- (c) Has made false statement(s) in the applicant's application with regard to any material fact or has practiced or attempted to practice any deception or fraud in the application or examination, in securing the applicant's eligibility, or appointment or promotion;
- (d) Was previously in the classified City Civil Service in the same or any other type of employment and was removed for cause or did not resign in good standing;

- (e) Has used or attempted to use any political pressure to further the applicant's eligibility for appointment or promotion;
- (f) Is addicted to the use of intoxicating liquor or narcotics or habit-forming drugs or addicted to gambling;
- (g) Had been convicted of a felony or a misdemeanor involving moral turpitude, violence, domestic violence, or controlled substances within the last seven years, or admitted to criminal activity determined to have a direct relationship to the position for which application is made. Such rejection, withholding, or removal shall take into consideration the seriousness of the offense, the age of the offense, and the age of the applicant at the time of its occurrence. Conviction of a felony shall automatically disqualify an applicant for any law enforcement officer position;
- (h) Has been dismissed from previous employment for delinquency or misconduct;
- (i) Refuses to furnish all information required to complete the application;
- (j) Is knowingly a member of any subversive organization that espouses illegal means to subvert an established and legally-constituted system or institution or who is knowingly a member of any organization which, to the applicant's knowledge, now advocates the overthrow of the government of the United States or of this State by force or violence or other unlawful means, or who now advocates the support of a foreign government against the United States in the event of hostilities;
- (k) Refuses to execute any oath or affirmation, as prescribed by law;
- (l) Fails to be present for fingerprinting;
- (m) Has assisted in preparing, conducting or scoring any examination for which the candidate applies or who has in any other manner secured confidential information concerning such examination which might give the applicant an unfair advantage over other applicants on the examination;
- (n) Fails to be present for or fails to pass the physical and/or medical examination;
- (o) Submits a written request that the applicant's name be removed from the eligibility list;

- (p) Failure to appear for a scheduled interview or to schedule an interview or other required appointment within the time period stated in the notice to do so, unless said applicant is on the promotional list and shall have specifically waived the applicant's right to a promotional appointment;
- (q) In any case where the Commission finds that an applicant is or has in any manner become disqualified for the position for which the applicant is listed, in accordance with these Rules;
- (r) Failure to notify the Secretary of changes in address;
- (s) Appointment to a permanent position through certification from an eligible list for an equivalent or higher rank;
- (t) In the case of promotional lists, upon separation from City employment, other than layoff from City service;
- (u) Failure to pass the polygraph examination or voice stress truth verification test for positions for which such examination and tests are required;
- (v) Failure to pass a pre-employment interview or background investigation, the purpose of which is to determine if the applicant had the background and ability to function as an effective Police Officer or Fire Fighter/Paramedic;
- (w) Failure to notify the Commission of receiving other employment or no longer being interested in seeking employment with the City for any other reason; or
- (x) Has applied to the City for a Lateral Transfer position in the last two (2) years.

## D. EXAMINATIONS

### Section 1. Types of Examination

Examinations shall be of three kinds:

- (a) Original Entry-Level Open Competitive (entrance) Examination;
- (b) Lateral Transfer Examination; and
- (c) Promotional Examination.

The Original Entry-Level Open Competitive, Lateral Transfer, and Promotional Examinations may be collectively referred to herein as "original entry level appointment." Examinations shall be written, oral and/or an assessment center format and of such a

character and relate to such matters as will, in the opinion of the Commission, fairly test the relative fitness of the persons examined to discharge the duties of the positions to which they seek appointment. All applicants for Original Entry-Level Open Competitive and Lateral Transfer appointments shall receive at least a minimum passing score of 70% on the written examination, as determined by the Commission. Based upon the ranking of scores on the written or other initial portion of the examination process, sufficient applicants in the opinion of the Commission to meet anticipated requirements of the Mayor shall then be required to continue with the remaining portions of the examination process, including the oral interview, prior to being ranked on the final eligibility list. Such applicants may be required to complete psychological testing and evaluation after a conditional offer of appointment has been made to the applicant.

Promotional examination applicants receiving at least a minimum passing score of 70% on the written examination may be required to complete psychological testing and evaluation.

## Section 2. Separate Examinations and Eligibility Lists for Police and Fire Fighter/Paramedics

Separate examinations shall be given and separate eligibility lists maintained by the Civil Service Commission for all classified civil service positions in the Fire and Police Departments. No person may be transferred from one list to the other. Appointments and promotions in said departments shall be only from the separate eligibility lists maintained for each of said departments. Transfers of personnel from one department to the other are hereby prohibited.

## Section 3. Examinations; Public Notice

Whenever the Mayor requests that the Commission certify names from an eligibility list for a vacant position for an Original Entry-Level position in the Police or Fire Departments or for a Promotional position in those Departments above the lowest grade, the Commission shall conduct an examination to create an eligibility list, if no such list exists for such position. For an Original Entry-Level Examination or a Lateral Transfer Examination, an eligibility list will be valid for one (1) year and no more than (2) years unless the Commission determines that the list is no longer valid after less than one (1) year due to lack of adequate, well-qualified applicants. For Promotional Examinations above the lowest grade, an eligible list shall be valid for not less than one (1) year nor more than two (2) years. At any time after the first year but before the end of the second year, the Commission may determine that the list is no longer valid. All examinations will be conducted within sixty (60) days of the Mayor's request for certification of names from an eligibility list when one is required, or as soon thereafter as is practical. The Commission may conduct an Original Entry-Level Open Competitive Examination, a Lateral Transfer

Examination, or both. Each type of examination will have its own separate and independent eligibility list.

Examinations shall be held under the direction of the Commission at such places as the Commission deems advisable. Public notice of the time and place of every examination shall be given at least 30 days prior to the date thereof on the bulletin board in City Hall. In addition, copies of said notices shall also be posted in the department for which the test is to be given.

Examination notices may be given in any written, printed or electronic form as designated by the Commission. Such notices shall also contain any other information relating to the scope of the examination(s), the weights, if any, to be attached to the various components of the examination(s), the qualifications of the applicants, and such other information as the Commission may deem proper.

#### Section 4. Development of Examination

Examinations shall be of such character and relate to such matters as will fairly test the relative fitness of the persons examined to discharge the duties of the positions to which they seek appointment. All examinations shall be based on objective and approved examination methods. Examination shall be conducted under the supervision of the Commission, and when necessary and advisable, Special Examiners may be designated by the Commission to assist in the conduct of the same.

#### Section 5. Safeguarding of Examinations; Candidate Identification Number

At the time of filing a candidate's application, each candidate shall be assigned an identification number by the Secretary of the Commission. All examination papers submitted by applicants shall contain their number only, and any record, written or electronic, bearing the name of an applicant or other identification mark that was caused by the applicant to be so identified or marked shall be rejected and the applicant shall be notified of disqualification.

#### Section 6. Marking or Score; College and Military Credits; Ranking on Eligibility List

Prior to the administration of an examination the Commission shall determine (i) the overall passing score; (ii) what percentage of the passing score shall be determined by each component or part of the examination process; and (iii) any minimum passing score for each component or part of the examination process. For examinations other than Promotional Examinations: (i) no credit shall be given for residency; (ii) not more than one point of the final score shall be added to the final grade of any person with a two (2)-year college degree from an accredited college or university or not more than two points of the final score be added to the final grade of any person with a four (4)-year college degree

from an accredited college or university, provided that the applicant has obtained at least the minimum passing grade on the written or other initial examination and further provided that copies of the applicant's college transcripts showing the degree are attached to the application at the time of filing the same; and (iii) no applicant shall receive more than two points total added to their scores for college degrees.

The Commission may also provide that no more than three points to be added to the scores of applicants who have completed at least one hundred and eighty (180) days of active duty U.S. military service, have received an honorable discharge, and have obtained at least the minimum passing score on the written or other initial examination, and further that the applicant has provided discharge documents or other proof of honorable U.S. military service.

No applicant can receive more than five points total added to their scores for college and/or military credit. No college or military credit will be added for Lateral Transfer examinations.

The Commission may contract with others to assist in the examination or evaluation of applicants.

All marking of scores shall be in accordance with the points and/or weight given for the respective components/parts of the examination and credit points established by the Commission and any outside examiner engaged by the Commission. Each component/part of the examination process must be passed or completed prior to proceeding to the next component/part.

The Commission shall have the absolute discretion to limit the number of interviews of applicants, based upon their ranking scores and depending upon the number of open positions to be filled. Therefore, interviews may be conducted when and if they are deemed required by the Commission.

Upon completion of the examination process as approved by the Commission, the Commission will add the various scores and credit points as determined by it to have been used for the particular examination process, or as otherwise provided in these Rules, and place the applicants on the eligibility list in their order of ranking based upon their final scores.

## Section 7. Inspection of Papers; Applicant's Right to Object

Any applicant for an examination who objects to the examination shall file a written notice of objection with the Secretary of the Commission as soon as reasonably possible, but not later than ten (10) calendar days prior to the examination.

Any applicant who objects to the conduct of the written or any other component/part of the examination shall file a written objection or protest with the Secretary of the Commission as soon as reasonably possible after the written or other examination component/part, but not later than five (5) calendar days after the administration of the written or other component/part of the examination.

Any applicant for an examination who objects to a question or the scoring on the written or other component/part of the examination shall file a written objection or protest within five (5) calendar days after the results of the written or other initial examination are posted. Applicants shall be notified by electronic mail of the posting of scores.

Any applicant for an examination who objects to or the final ranking after the examination process is completed shall file an objection with the Secretary of the Commission as soon as reasonably possible, but not later than five (5) calendar days after the final ranking is posted.

Any applicant shall have the right, at any time within the period of five (5) calendar days after the results of the written or other initial examination are posted, to review the applicant's own answer sheets and inform the applicant as to the markings given the applicant on each subject or question and to submit in writing for the Commission's consideration, any objections or protest the applicant may wish to make concerning a question or the scores given the applicant.

No objection or protest concerning an examination, not submitted in writing, shall be considered unless it relates to the conduct of examiners, the securing of unlawful assistance by a competitor or such other circumstances in connection with an examination as would call for an investigation on the part of the Commission, and which would require that the information submitted be given in confidence.

An applicant who exercises the right to inspect the examination papers shall not be permitted to take an examination again for the same classification within a six-month period following the inspection, unless an alternate form of examination is given. At the sole discretion of the Commission, inspection of standardized tests prepared by experts outside of the City may not be permitted, where such inspection would tend to reduce the validity of current and future test results.

The Commission will consider the objections and take such action as the circumstances warrant, and its findings shall be final.

Any clerical error may be corrected by the Secretary upon discovery at any time during the life of the eligibility list, but no such correction shall affect an appointment from a certification made prior to the correction.

#### E. CORRESPONDENCE

##### Section 1: Notification of Grade and Placement on Eligibility List

All applicants shall be notified in writing by the Secretary of the Commission at the last electronic mail and U.S. Mail address, as shown by the records of the Commission, of the applicant's grade on the written or other component/part of the examination and again when an applicant is to be placed on the eligibility list.

##### Section 2: Notification of Certification to Mayor from Eligibility List

Each eligible candidate shall be notified in writing by the Secretary of the Commission when certified to the Mayor for appointment. Such notice shall include that a background check may be performed and that the candidate may be required to appear for an interview with the Mayor. Such notice shall be sent by electronic mail and U.S. regular Mail to the last address of the eligible candidate as shown by the records of the Commission.

##### Section 3: Reports from Appointing Authority

The Mayor shall make a written report to the Commission indicating whether any of the persons certified in the pool failed to appear for a scheduled interview, whether a candidate was or candidates were selected for appointment from the pool and given a conditional job offer pending the results of the required physical examination, and whether any of the candidates declined or waived appointment.

##### Section 4: Notification of Pass Over and Results of Physical Examination upon Conditional Job Offer

The Secretary of the Commission shall notify in writing any candidate not chosen for appointment. This notification shall be done upon verification from the Police Chief or the Fire Chief that another candidate has verbally accepted appointment.

The Secretary of the Commission shall notify the Mayor in writing upon receipt of notification of the results of the physical examination of a candidate who has been given a conditional job offer.

## Section 5: Notification of Address Change

Every candidate and each person whose name appears on an eligibility list shall file with the Commission a written notice of any change in the candidate's electronic mail and U.S. Mail address. Such notice shall state the candidate's name, the eligibility list on which the candidate's name appears, the candidate's new address(es), and the candidate's last address(es) as registered with the Commission. Failure to do so may result in such candidate's name being removed from the list.

## Section 6: Canvass of Eligibility Lists

Whenever the Secretary of the Commission believes the needs of the classified Civil Service require, the Secretary shall ascertain through written correspondence or telephone authorization the availability for employment of persons whose names appear on an eligibility list.

## F. ELIGIBILITY LIST

### Section 1. Development of List

Sufficient candidates in the opinion of the Commission to meet the anticipated requirements of the Mayor to fill a position shall be required to pass the psychological tests, if required to be administered, in order to proceed with the interview process.

Duly qualified applicants shall be placed on the eligibility list and ranked in the order of their final scores after the scores are totaled and points are added for credits (if applicable), and as otherwise provided in these Rules.

Whenever the Mayor determines to fill a vacancy for a position in the Police and Fire Departments, the Mayor shall request that the Commission certify names from the appropriate eligibility list.  
(Beachwood Charter, Article VI, Section 3, 3(E) (1)).

### Section 2. Priority

When two or more eligible applicants have received the same score, the person first filing an application, or, if the examination is for promotion, the person with the longest seniority in the department, shall have priority.

### Section 3. Duration

The date of certification shall be clearly shown on all eligibility lists. All eligibility lists for promotional positions shall be valid for not less than one (1), nor more than two (2) years. At any time after the first year, but before the end of the second year, the Commission may declare that the list is no longer valid. For Original Entry-Level positions and Lateral Transfer positions, an eligibility list will be valid for one (1) year and no more than two (2) years unless the Commission determines that the list is no longer valid after less than one (1) year due to the lack of adequate, well-qualified applicants.

### Section 4. Disqualification

If, at any time, the Commission has reason to believe that any person, upon the eligibility list, has in any manner become disqualified for the position sought as indicated at Article C, Sections 6 and 7, herein, a notice to such person and an opportunity to be heard, in the person's own behalf, shall be given. Upon failure to satisfy the Commission that the person is duly qualified, said name shall be removed from such eligibility list.

## G. CERTIFICATION AND APPOINTMENT

### Section 1. Certification and Examination Criteria

(a) Examinations of applicants for the eligibility list for Original Entry-Level Open Competitive appointment for Police Officer shall be based upon the following factors:

Maximum 100 points on WRITTEN EXAMINATION

Maximum 10 points on ORAL INTERVIEW WITH CIVIL SERVICE COMMISSION

Maximum 10 points on POLICE DEPARTMENT ASSESSMENT

(b) Examinations of applicants for the eligibility list for Original Entry-Level Open Competitive appointment for Fire Fighter/Paramedic shall be based upon the following factors:

Maximum 100 points on WRITTEN EXAMINATION

Maximum 20 points on ORAL INTERVIEW WITH CIVIL SERVICE COMMISSION

Maximum 30 points on FIRE DEPARTMENT ASSESSMENT

(c) Examinations of applicants for the eligibility list for Lateral Transfer appointments in the Police Department shall be based on the following factors:

Maximum 100 points on POLICE DEPARTMENT ASSESSMENT

(d) Examinations of applicants for the eligibility list for promotion shall be based upon the following factors:

(i) For Fire Captain Promotions

40% WRITTEN EXAMINATION  
60% ASSESSMENT CENTER

(ii) For Fire Lieutenant Promotions

60% WRITTEN EXAMINATION  
40% ASSESSMENT CENTER

(iii) For Police Lieutenant Promotions

40% WRITTEN EXAMINATION  
60% ASSESSMENT CENTER

(iv) For Police Sergeant Promotions

60% WRITTEN EXAMINATION  
40% ASSESSMENT CENTER

## Section 2. Certification and Selection by Mayor; Probationary Period

(a) Upon receipt of notice from the Mayor that a vacancy exists for an original entry level appointment, the Commission shall certify to such appointing authority the names of the ten (10) persons ranked highest on the eligibility list for that position. The Mayor shall appoint one (1) of the ten (10) to fill the office.

(b) If there is more than one (1) vacancy to be filled for an original entry level appointment, the number of names to be certified shall be determined in the following manner:

(i) The Commission shall certify ten (10) names from the eligibility list for one (1) position to be filled plus two (2) names for each additional position to be filled. (i.e., two positions open - certify twelve names, three positions open – certify fourteen names).

(ii) The Mayor shall consider each candidate so certified for an Original Entry-Level appointment. When both an Original Entry-Level eligibility list and a Lateral Transfer eligibility list are in effect at the same time, the Mayor may appoint a

candidate from either list. select potential hires from only one eligibility list.

- (iii) If an eligibility list contains less than ten (10) names, the Mayor may accept the lesser number and appoint from such list, or may require a new list of ten (10) names for each position to be filled.

The candidate selected for appointment shall be duly notified by the Mayor, and if the person so selected shall fail to respond within four (4) calendar days to the notice of appointment sent by electronic mail or by registered or certified mail to the appointee's address(es) as registered with the Commission, said person shall be stricken from the eligibility list. If, however, it shall be made to appear to the satisfaction of the Commission within thirty (30) days after giving such notice that the person was unavoidably and without fault prevented from accepting said appointment, the name may be restored to its proper position on the eligibility list.

Certification for promotional appointments shall be governed by Article K herein.

Original Entry-Level and Promotional appointments in the classified Civil Service shall be for a probationary period of one (1) year from the date of appointment but with the exception of Original Entry-Level Police Officers who shall be for a probationary period of one (1) year after successful completion of their field training. All probationary appointees are subject to removal from their positions by the Mayor during such one (1)-year period without appeal to the Civil Service Commission. No appointment shall be deemed final until the appointee has satisfactorily served the probationary period.

#### H. POLITICAL ACTIVITY

Persons holding positions in the classified service shall not be discriminated against in any way because of their political opinions or political affiliations, or because of the exercise of their right to vote as they please and to express their opinions on political subjects. However, they shall take no active part in political management or political campaigns; and they shall neither act as officers of election committees nor be officers in any political organization.

Nothing in this article prohibits an officer or employee from serving as a precinct election official under section 3501.22 of the Revised Code, but an officer or employee who serves as a precinct election official must use vacation leave to so serve.

## I. PAPERS: PROPERTY OF THE COMMISSION

All original papers, applications, examination papers, answer sheets, questions, certificates, etc., are the property of the Commission and must be filed in the office of the Commission and kept for not less than three years, except the examination papers of those failing to pass, which may be destroyed after ninety days.

## J. TEMPORARY AND EMERGENCY APPOINTMENTS

### Section 1. Temporary Appointments

Upon receipt of request for certification for a position for which no appropriate eligibility list is available, the Commission shall notify the Mayor that nomination for temporary appointment may be made to fill such position until an eligibility list can be created, or for a period not to exceed ninety days.

### Section 2. Emergency Appointments

Emergency appointments may be made by the Mayor when, in the judgment of the Mayor, the good of the service, the health, safety or welfare of the public, and/or the necessities of the City's operation make it necessary to do so. Written notice, however, must be given forthwith to the Commission, together with the reasons for making such emergency appointments, and such reasons must be sufficient and satisfactory to the Commission. The emergency appointment shall not be effective for a period longer than ninety days.

## K. PROMOTIONS

### Section 1. Examination for Promotions

Whenever the Mayor requests that the Commission certify names from an eligibility list for a vacant position in the Departments of Police and Fire above the lowest grade, the Commission shall, if no list exists, conduct an examination consistent with Article D of these Rules, to create an eligibility list, which shall be valid for not less than one (1) nor more than two (2) years. At any time after the first year, but before the end of the second year, the Commission may determine that the list is no longer valid.

Applicants for promotion shall be examined on such practical and theoretical questions as in the judgment of the Commission pertain to the office or rank to which promotion is sought, upon the State Laws, the City Ordinances, Rules and Regulations pertaining to the duties of said office or rank, and upon such other subjects or tests which the Commission may prescribe.

## Section 2. Eligibility List for Promotions

Before conducting an examination for a promotional position, the Commission shall ascertain whether there are at least two (2) persons who are eligible and willing to take a competitive examination to fill such vacancy.

- (a) If at least two (2) such persons take and pass the examination for a promotional position, the Mayor shall appoint one (1) of the persons from such list.
- (b) If only one (1) person passes the examination for a promotional position and/or the Mayor objects to one (1) name on the eligibility list, or if no person passes the examination, the Commission shall conduct another examination permitting all persons in the next lower rank below the rank to be filled and eligible persons in the second next lower rank below the rank to be filled, to compete.
- (c) To be eligible for a promotional examination for the rank next above Patrol Officer in the Police Department or next above the rank of Fire Fighter in the Fire Department, a person must have served at least thirty-six (36) months continuously in the lower rank, including probationary time. To be eligible for a promotional examination for other higher ranks, a person must have continuously served at least one (1) year in the next lower rank. In the event of circumstances not covered by these Rules, the Commission shall determine the required eligibility which shall require not less than one (1) year of continuous service in a lower rank.
- (d) Promotional applicants may be required to complete psychological testing and evaluation.

## Section 3: Certification for Appointment for Promotions

After the promotional examination has been graded, and subject to Section 2 (b) above or upon the Mayor's request if an eligibility list exists, the Commission shall certify to the Mayor the names and grades of the five (5) persons ranking highest or such lesser number as appears on the eligibility list. The Mayor shall promote one (1) of such persons within thirty (30) days after certification, provided at least two (2) persons remain on the eligibility list. The Mayor may appoint the remaining person if only one (1) name remains on the list, or may request that the Commission conduct another examination subject to Section 2 (b) above. If any person is not appointed after being certified for consideration for appointment to a vacant position three (3) times, such person shall be removed from the eligibility list.

Section 4. Notice of Examination

Notice of all promotional examinations shall be posted by the Secretary in a conspicuous place in the City Hall and upon the collective bargaining unit's bulletin board in the applicable Department not less than thirty (30) days before the date fixed for the examination. Such notice shall give the date and the character of the examination and shall indicate the grade or rank of persons eligible to compete. Applicants for promotion shall file their applications as the Commission has prescribed in its notice.

L. WAIVER OF RULES

In specific cases where, in the sole discretion of the Commission, it is in the interest of the public service, any of the rules hereby adopted may be waived by the unanimous vote of all three members of the Commission; provided, however, that such waiver shall not be inconsistent with the provisions of the Charter and ordinances of the City of Beachwood or where applicable, the laws of the State of Ohio. Such action, together with the reasons therefor, shall be entered in the minutes of the Commission. In the interest of justice to all concerned and to promote the welfare of the Civil Service in the City of Beachwood, Ohio a wide degree of liberality of construction and interpretation of these Rules and Regulations in any and all circumstances and situations shall be the policy to be adopted and followed by the Commission in its administration of the Civil Service system.

I, WHITNEY M CROOK, Clerk of Council & Secretary to the Civil Service Commission, do hereby certify that the foregoing is a true and correct copy of the Rules of the Civil Service Commission of the City of Beachwood, Ohio (as revised \_\_\_\_\_, 2026).

Date: \_\_\_\_\_

*WHITNEY M. CROOK*

Clerk of Council / Civil Service Commission Secretary  
City of Beachwood, Ohio

A RESOLUTION AUTHORIZING THE MAYOR TO ENTER INTO A MEMORANDUM OF UNDERSTANDING WITH THE CUYAHOGA SOIL AND WATER CONSERVATION DISTRICT AND THE NORTHEAST OHIO REGIONAL SEWER DISTRICT FOR THE PROVISION OF TECHNICAL ASSISTANCE FOR THE CITY OF BEACHWOOD'S COMPLIANCE WITH THE OHIO EPA'S NATIONAL POLLUTANT DISCHARGE ELIMINATION SYSTEM ("NPDES") PERMIT REQUIREMENTS; AND DECLARING THIS TO BE AN URGENT MEASURE

WHEREAS, the Cuyahoga County Soil and Water Conservation District ("SWCD") can provide services to the City required by Ohio EPA's National Pollutant Discharge Elimination System ("NPDES") General Permit for Municipal Separate Storm Sewer Systems ("MS4s") (NPDES Phase II) requirements as set forth in the City's Stormwater Management Plan and has offered to do so by a Memorandum of Understanding in years 2026 through 2030 (the "MOU"); and SWCD has previously provided such services to the City under previously approved MOUs;

WHEREAS, the Northeast Ohio Regional Sewer District ("NEORS") is required to provide Phase II stormwater regulation support services to member communities for Minimum Control Measure Nos. 1, 2, 3, and 6 under NEORS's Regional Stormwater Management Code (Title V), and is further authorized to provide such services through agreements with service providers such as SWCD;

WHEREAS, the MOU by and between the City, SWCD and NEORS will provide services for the implementation of conservation education, stewardship, and public involvement activities that also correspond to the City's Municipal Separate Storm Sewer System (MS4) permit requirements (the "Services"); and

WHEREAS, this Council believes it is in the best interest of the City to enter into the MOU with the SWCD and NEORS for the provision of the Services for an annual disbursement by the City to SWCD in an amount not to exceed Six Thousand Six Hundred Dollars (\$6,600), as appropriated by this Council, for each of the years 2026 through 2030, which amount will be reimbursed by NEORS upon an application thereto.

NOW, THEREFORE, BE IT RESOLVED by the Council of the City of Beachwood, County of Cuyahoga, and State of Ohio, that:

Section 1: The Mayor is hereby authorized to enter into a Memorandum of Understanding (MOU) with the Cuyahoga Soil and Water Conservation District, and the Northeast Ohio Regional Sewer District as set forth in the recitals to this Resolution, for a term beginning January 1, 2026, and ending December 31, 2030, in an amount not to exceed \$6,600 annually, as will be appropriated by this Council, which amount will be reimbursed by NEORS, upon application thereto, as set forth in the MOU.

Section 2: It is found and determined that all formal actions and deliberations of Council and its committees, relating to the passage of this legislation that resulted in formal action were in meetings open to the public where required by Chapter 105 of the Codified Ordinances of the City.

RESOLUTION NO. 2026-35

Section 3: This Resolution is declared to be an urgent measure necessary for the preservation of the public peace, health, safety, or the efficient operation of the City; and for the further reason to ensure continued compliance with applicable state and federal stormwater regulations.; wherefore, this Resolution shall be in full force and effect immediately upon its passage and approval by the Mayor.

Attest: I hereby certify this legislation was duly adopted on the 9<sup>th</sup> day of March, 2026, and presented to the Mayor for approval or rejection in accordance with Article III, Section 8 of the Charter on the 10<sup>th</sup> day of March, 2026.

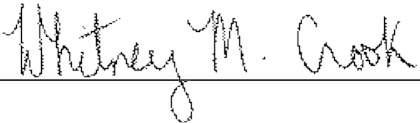
  
\_\_\_\_\_  
Clerk

Approval: I have approved this legislation this 10<sup>th</sup> day of March, 2026 and filed it with the Clerk.

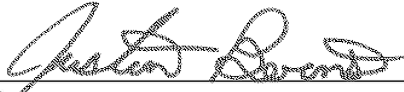
  
\_\_\_\_\_  
Mayor

# **BEACHWOOD PUBLIC WORKS DEPARTMENT INTER-OFFICE MEMORANDUM**

**TO:** Mayor Justin Berns

**FROM:** Chris Arrietta, Public Works Director

**DATE:** February 23, 2026

**RE:** Council Agenda Item: Memorandum of Understanding – CSWCD/NEORS

---

The Cuyahoga Soil and Water Conservation District (CSWCD) currently provides Public Involvement and Public Education (PIPE) services to the City each year to support stormwater awareness initiatives, conservation education, and compliance with Phase II regulations.

The annual program includes the following components:

## **Public Education**

- Development and distribution of print and digital educational materials
- Targeted mailings to residents
- Public presentations
- Materials and staffing support for community events

## **Public Involvement**

- Programs and workshops for residents and property owners
- Support for community-based volunteer initiatives
- Administration of watershed pledges, practices, and behavior programs

## **Program Administration**

- Annual coordination meetings with City staff
- Development of outreach strategies and identification of community priorities
- Assistance with the City's Stormwater Master Plan (SWMP)
- Phase II regulatory review and support

The annual cost of the program is \$6,600.00. The proposed agreement will run from 2026 through 2030 for a total amount not to exceed \$33,000.00. The Northeast Ohio Regional Sewer District (NEORS) will reimburse the City annually for the full cost of the program.

**MEMORANDUM OF UNDERSTANDING for 2026-2030  
Between Cuyahoga Soil & Water Conservation District  
and the  
Northeastern Ohio Regional Sewer District  
and the City of Beachwood**

This Memorandum of Understanding (“MOU”) is made effective as of the 1<sup>st</sup> day of January, 2026 (“Effective Date”), between Cuyahoga Soil & Water Conservation District (“Cuyahoga SWCD”) and the Northeastern Ohio Regional Sewer District (“NEORSRD”), pursuant to the authority of Board Resolution 17-26, adopted February 5, 2026 and the City of Beachwood (“City”), referred to herein as the “Parties,” to provide technical support in meeting the Ohio EPA’s National Pollutant Discharge Elimination System (NPDES) General Permit for Municipal Separate Storm Sewer Systems (MS4s) (NPDES Phase II) requirements for the following Minimum Control Measures (MCMs):

- MCM #1- Public Education and Outreach
- MCM #2- Public Participation

**BACKGROUND AND PURPOSE**

Recognizing the need for effective collaboration in raising awareness through education, stewardship opportunities and public involvement and working to change the perceptions and behaviors of the public for a cleaner, healthier environment, such as what is required in the National Pollutant Discharge Elimination System (NPDES) permit, the City, Cuyahoga SWCD, and NEORSRD accept this agreement as the document which describes the process for exchange. Cooperation between these units of government facilitates better awareness of environmental issues and involvement in potential solutions for a healthier environment. In providing conservation education assistance and expertise to the City, Cuyahoga SWCD hopes to influence citizens to better protect and conserve soil and water resources both locally and throughout Ohio. Ohio Revised Code, Chapter 940, describes Cuyahoga SWCD’s authority for engaging in this MOU.

Additionally, NEORSRD is required to provide Phase II stormwater regulation support services to member communities for Minimum Control Measures #1, #2, #3, and #6 under NEORSRD’s Regional Stormwater Management Code (Title V) and is further authorized to provide such services through agreements with service providers such as Cuyahoga SWCD.

Cuyahoga SWCD, NEORSRD, and the City have mutually agreed to this scope of assistance related to education, stewardship, and public involvement for the conservation of soil and water resources.

## **ANNUAL PROGRAM TASKS**

Cuyahoga SWCD will work with the City and NEORSD to provide an annual Public Involvement and Public Education (PIPE) program that meets performance standards for MCMs #1 and #2, as established by the City's OEPA-issued stormwater permit. The following tasks will be completed annually as part of the PIPE program implementation:

### Public Education

- Creation and distribution of printed and digital materials related to the annual outreach theme and targeted messages.
- Links to publicly accessible education and outreach materials and articles on the Cuyahoga SWCD website.
- Targeted mailings to a minimum of 10% of City households annually (50% of households reached over the life of the MOU).
- Public presentations on a range of local conservation topics for community groups, elected officials, and other audiences as requested.
- Providing materials and/or staff tabling support for community events such as Home Days, Earth Day, and Arbor Day events as requested.
- Offering educator professional development opportunities, including classroom and hands-on training in curriculum supplements such as Project WET and Project Learning Tree and leading Meaningful Watershed Education Experiences.
- Providing schools presentations and activities aimed at youth education such as Enviroscape, water quality testing, and soil erosion models.

### Public Involvement

- Providing programs and workshops for residents and other landowners to learn about and improve onsite stormwater management on their properties.
- Supporting community-based volunteer activities such as stream cleanups, tree planting, storm drain stenciling, and rain garden installation/maintenance.
- Administering conservation pledges for residents to adopt watershed-friendly practices or behaviors.

### Program Administration

- Development of MOU and annual MOU renewal process.
- Tracking MOU renewal status, payments, and reimbursement through NEORSD.
- Annual meeting with assigned Cuyahoga SWCD staff lead to understand community priorities and engagement opportunities.
- Development of an annual Outreach Strategy, outlining targeted audiences, stormwater messages, message delivery mechanisms, public involvement activities, TMDL goals (where applicable), and other community priorities.
- Support updating language in City's Stormwater Master Plan (SWMP) related to MCMs #1 and #2.

- Documenting all PIPE program activities completed throughout the year and support with annual permit report in Ohio EPA's STREAMS online reporting system as requested.
- Audit support for Ohio EPA audits of MCMs #1 & #2 as requested, including providing any requested documentation to Ohio EPA.
- Community survey conducted once per permit term to assess changes in community stormwater awareness and knowledge, and rates of adoption of residential stormwater management practices.

## **MOU PARTNER ROLES & RESPONSIBILITIES**

### Cuyahoga SWCD Responsibilities:

Through this MOU, Cuyahoga SWCD will be responsible for the following:

- 1) Cuyahoga SWCD will lead the annual MOU renewal process, including tracking MOU renewal status, payments, and reimbursement requests submitted to NEORS.
- 2) Cuyahoga SWCD will coordinate an annual meeting between City and assigned Cuyahoga SWCD staff to understand community priorities and engagement opportunities.
- 3) Cuyahoga SWCD will lead implementation of Public Education and Public Involvement activities as outlined in the Annual Program Tasks section above.
- 4) Cuyahoga SWCD will work with the City to develop an annual Outreach Strategy to outline targeted audiences, messages, delivery mechanisms, public involvement activities, TMDL goals (where applicable), and other community priorities.
- 5) Cuyahoga SWCD will provide updated language to the City for inclusion in its Stormwater Master Plan (SWMP) related to MCMs #1 and #2.
- 6) Cuyahoga SWCD will document all PIPE program activities completed throughout the year and providing support with annual permit report in Ohio EPA's STREAMS online reporting system as requested.
- 7) Cuyahoga SWCD will provide audit support for Ohio EPA audits of MCMs #1 & #2 as requested, including providing any requested documentation to Ohio EPA.
- 8) Cuyahoga SWCD will conduct a community survey once per permit term to assess changes in community stormwater awareness and knowledge, and rates of adoption of residential stormwater management practices.

### City's Responsibilities:

Through this MOU, the City will be responsible for the following:

- 1) The City will provide an annual appropriation of \$6,600.00 to Cuyahoga SWCD for implementation of the City's annual PIPE program. Should additional services be requested outside the scope of this MOU, written amendments will be made and additional costs agreed upon by both parties. This memorandum of understanding will be reviewed each year to ensure agreed upon assumptions are still valid.

- 2) The City will designate one or more individual(s) to serve as the City's liaison(s) to Cuyahoga SWCD for implementation of the annual PIPE program. The designated individual will be responsible for the following:
  - a. Meeting with Cuyahoga SWCD staff annually to review annual PIPE program deliverables, Outreach Strategy, and community priorities.
  - b. Identifying target audiences and community event opportunities for the PIPE program.
  - c. Supporting Cuyahoga SWCD staff in coordinating community workshops, volunteer events, or other public involvement activities conducted as part of the City's annual PIPE program.
  - d. Distributing relevant program information to residents, business/property owners, or other audiences in a timely manner.
- 3) The City will assume full responsibility for completion and submittal of required Ohio EPA annual reports under the NPDES Phase II program.
- 4) The City will provide a resolution to Cuyahoga SWCD acknowledging this working agreement and providing documentation to facilitate dispersal of funds to Cuyahoga SWCD on an annual basis.

NEORSD's Responsibilities:

Through this MOU, NEORSD will be responsible for the following:

- 1) In accordance with Title V of NEORSD's Regional Stormwater Management Code, NEORSD will provide an appropriation in the amount of \$ 6,600.00 to the City, which shall use such appropriation as reimbursement for payments made to Cuyahoga SWCD to carry out the services set forth in this MOU.
- 2) NEORSD will coordinate with Cuyahoga SWCD and the City to review PIPE program deliverables, Outreach Strategy, and community priorities on an annual basis.
- 3) NEORSD will provide quarterly reports to Cuyahoga SWCD detailing reimbursement status for payments made to Cuyahoga SWCD for the services set forth in this MOU.

**GENERAL TERMS OF UNDERSTANDING**

- 1) The Parties recognize that Cuyahoga SWCD has expertise in compliance with the requirements of the OEPA's NPDES Phase II regulations specific to MCMs #1 and #2 and are relying on such expertise to implement an effective annual Public Involvement and Public Education program.
- 2) The Parties recognize that Cuyahoga SWCD does not hold regulatory authority under Ohio Revised Code or OEPA's NPDES Phase II General Permit.
- 3) All Parties will review quality of assistance and address concerns as they arise.
- 4) All assistance provided by Cuyahoga SWCD is offered on a non-discriminatory basis without regard to race, age, marital status, handicap or political persuasion.
- 5) All Parties recognize Cuyahoga SWCD's obligation to make its reports and/or other written materials available to the public on request in accordance with the Ohio Public Records Act.

- 6) Any notice or communication required or permitted under this MOU shall be sufficiently given in writing delivered in person or electronic mail, to the following:

<b>NORTHEAST OHIO REGIONAL SEWER DISTRICT</b>	<b>CUYAHOGA SOIL &amp; WATER CONSERVATION DISTRICT</b>
MATT SCHARVER, DIRECTOR OF WATERSHED PROGRAMS	KRISTIN N. HALL FITZGERALD, EXECUTIVE DIRECTOR
SCHARVERM@NEORS.D.ORG	KHALL@CUYAHOGASWCD.ORG
CLEVELAND, OHIO 44115	CLEVELAND, OHIO, 44114
<b>CITY OF BEACHWOOD</b>	
[FIRST NAME, LAST NAME, JOB TITLE]	
[EMAIL ADDRESS]	
[CITY], OHIO, [ZIP CODE]	

- 7) In the event of any dispute or disagreement between any of the Parties with respect to the interpretation of any provision of this MOU which cannot be resolved in the normal course of business, then upon written notice of either party to the other adhering to the following:
- a. Each party agrees to meet for the purpose of endeavoring in good faith to resolve the dispute;
  - b. No formal action for such dispute may be commenced by the parties until either of the parties concludes in good faith that amicable resolution through continued negotiation of the matter at issue does not appear likely and so notifies the other party; and
  - c. The rights and obligations of the Parties under this Section shall not limit either Party's right to terminate this MOU as otherwise permitted hereunder.
- 8) This MOU shall be governed by and construed in accordance with the laws of the State of Ohio.
- 9) In the event that any provision of this MOU is deemed to be severable or invalid, and if any term, condition, phrase or portion of this MOU shall be determined to be unlawful or otherwise unenforceable, the remainder shall remain in full force and effect, so long as the clause severed does not affect the intent of the Parties. If a court should find that any provision of this MOU to be invalid or unenforceable, that provision will be changed and interpreted to accomplish the Parties' objectives to the greatest extent possible under applicable law and the remaining provisions of this MOU shall continue in full force and effect.
- 10) There are no third party beneficiaries under this Contract, and in no event shall Cuyahoga SWCD be liable to the City or NEORS.D for incidental or consequential damages of any kind, including, without limitation, punitive or economic damages or lost profits.
- 11) No Party under this MOU may assign or transfer the responsibilities or agreement made herein without the prior written consent of the non-assigning party, from which approval shall not be unreasonably withheld.

- 12) This MOU constitutes the entire understanding of the Parties pertaining to all matters contemplated hereunder at this time. The Parties signing this MOU desire or intend that any implementing contract or other agreement entered into between the parties in writing subsequent hereto shall supersede and preempt any conflicting provision of this MOU. The terms of this MOU control over any conflicting terms in any referenced document.
- 13) By entering into this MOU, the Parties agree on behalf of themselves and their respective officers, employees, agents or assigns, that this transaction may be conducted by electronic means by agreeing that all documents requiring signatures by Cuyahoga SWCD, NEORSD, and the City may be executed by electronic means, and that the electronic signatures affixed by Cuyahoga SWCD, NEORSD and the City to said documents shall have the same effect as if that signature was manually affixed to a paper version of the document.

### **INDEMNIFICATION**

Cuyahoga SWCD, NEORSD, and the City do not indemnify any person or entity, and agree that no provision of this MOU or any other agreement between Cuyahoga SWCD, NEORSD, and the City may be interpreted to obligate either to indemnify or defend the other or any other person or entity. Each party agrees to be responsible for any and all damages resulting from the actions or omissions of its officers, officials, employees and agents while same are engaged in the performance of this MOU.

### **TERM, RENEWAL, TERMINATION**

The term of this MOU shall commence on January 1, 2026 or the date ("Initial Effective Date") Cuyahoga SWCD receives written notice from the City, in a form approved by Cuyahoga SWCD and in accordance with Sections 5705.41 and 5705.44 of the Ohio Revised Code, as applicable, indicating that the City has agreed to appropriate annual funds, in the amount of \$6,600.00 per year, to support implementation of the City's annual PIPE Program for each following 12-month period. This MOU shall expire December 31, 2030 or five (5) years after the Initial Effective Date, unless this MOU is terminated sooner, or unless the MOU is extended by the City.

The MOU shall continue in effect for said periods, unless the MOU is terminated sooner, or unless it is further extended by mutual agreement, in writing, of the parties hereto. Any such extension shall be under the same terms and conditions as set forth in this MOU.

This MOU may be amended or terminated at any time by mutual consent of all Parties, or the agreement may be terminated by any party giving thirty (30) day's advance written notice to the other Parties.

In witness thereof, the Memorandum of Understanding executed and agreed to on the latest day, month and year written below:

**CUYAHOGA SOIL & WATER  
CONSERVATION DISTRICT**

**CITY OF BEACHWOOD**

\_\_\_\_\_  
(Signature)

\_\_\_\_\_  
(Signature)

BY: \_\_\_\_\_  
(Printed Name, Title)

BY: \_\_\_\_\_  
(Printed Name, Title)

DATE: \_\_\_\_\_

DATE: \_\_\_\_\_

**NORTHEAST OHIO REGIONAL SEWER DISTRICT**

\_\_\_\_\_  
(Signature)

BY:     Kyle Dreyfuss-Wells, Chief Executive Officer \_\_\_\_\_  
(Printed Name, Title)

DATE: \_\_\_\_\_

\_\_\_\_\_  
(Signature)

BY:     Darnell Brown, President, Board of Trustees \_\_\_\_\_  
(Printed Name, Title)

DATE: \_\_\_\_\_

<p>This Instrument Reviewed By: Katarina K. Waag Assistant General Counsel Northeast Ohio Regional Sewer District</p>
---

[FOR NEORS D USE ONLY]

AGREEMENT NO.

NORTHEAST OHIO REGIONAL SEWER DISTRICT

WITH

CUYAHOGA SOIL & WATER CONSERVATION  
DISTRICT

AND

CITY OF BEACHWOOD

FOR

2026 – 2030 PHASE II STORMWATER REGULATION  
SUPPORT

**CERTIFICATION**

---

**Total Amount Not-to-Exceed: \$33,000.00**

2026 - \$6,600.00  
2027 - \$6,600.00  
2028 - \$6,600.00  
2029 - \$6,600.00  
2030 - \$6,600.00

---

It is hereby certified that the amount required to meet the contract, agreement, obligation, payment or expenditure, for the above, has been lawfully appropriated or authorized or directed for such purpose and is in the Treasury or in process of collection to the credit of the fund free from any obligation or certification now outstanding.

The legal form and correctness of the within instrument are hereby approved.

---

ERIC J. LUCKAGE  
CHIEF LEGAL OFFICER

---

KENNETH J. DUPLAY  
CHIEF FINANCIAL OFFICER

---

Date

---

Date



3311 Perkins Ave. Suite 100  
Cleveland, OH 44114  
216.524.6580  
cuyahogawcd.org

February 19, 2026

Hon. Mayor Justin Berns  
City of Beachwood  
(Letter via Email)

**Re: 2026–2030 Memorandum of Understanding Agreement Renewal of PIPE Services (NPDES Phase II Permit, Minimum Control Measures #1 and #2)**

Dear Mayor,

Since 2017 your community has partnered with Cuyahoga Soil & Water Conservation District (SWCD) and the Northeast Ohio Regional Sewer District (NEORS) for services related to your community's mandated Public Involvement and Public Education (PIPE) program under the Ohio EPA Municipal Separate Storm Sewer System (MS4) Permit.

Under the MS4 Permit, your community is required to develop, implement, and enforce a Stormwater Management Plan that addresses six Minimum Control Measures, two of which are:

- MCM #1: Public Education and Outreach
- MCM #2: Public Participation and Involvement

Together MCM #1 and #2 make up the PIPE Program (Public Involvement, Public Education). Criteria for the PIPE Program is to identify stormwater pollution concerns, have measurable goals, reach a variety of audiences, actively involve potentially affected stakeholder groups, and evaluate the program's success. All of this must be reported annually to Ohio EPA.

Through a five-year Memorandum of Understanding (MOU), Cuyahoga SWCD implements your community's annual PIPE Program. Enclosed you will find the 2026–2030 MOU for Cuyahoga SWCD to continue providing PIPE Program services through December 31<sup>st</sup>, 2030. The annual cost for the PIPE Program is \$6,600.00, which is invoiced annually and eligible for reimbursement by NEORS.

Upon signing and execution of the 2026–2030 MOU, Cuyahoga SWCD will submit the 2026 invoice for services. After payment is received by Cuyahoga SWCD, a reimbursement request will be submitted to NEORS on your community's behalf. Payments received before July 2026 will be submitted for reimbursement on a monthly basis, then quarterly July–December 2026. See the enclosed flow chart for a summary of the 2026 PIPE Program Administration, including target completion dates.

*Our Land. Our Water. Our Future.*



3311 Perkins Ave. Suite 100  
Cleveland, OH 44114  
216.524.6580  
[cuyahogawcd.org](http://cuyahogawcd.org)

**Cuyahoga SWCD is requesting the 2026-2030 MOU to be signed by your community and returned by Friday, March 13<sup>th</sup>, 2026.** Please contact us if your community's administrative policies will not allow you to sign the MOU by this date.

Please feel free to contact Jared Bartely, Deputy Director of Watershed & Education Programs, or myself if you have any questions or if there is any additional information we can provide. We appreciate your ongoing partnership in educating and engaging your community in stormwater awareness and environmental stewardship.

Sincerely,

A handwritten signature in black ink, appearing to read "K. Fitzgerald". The signature is fluid and cursive.

Kristin Hall Fitzgerald  
Executive Director

CC:

Jared Bartley, Deputy Director Watershed & Education Programs  
Teresa Haendiges, Fiscal & Administrative Specialist  
Christina Znidarsic, Board Chair



# PIPE Program

## Stormwater Public Involvement & Public Education in Your Community

Cuyahoga SWCD's PIPE Program is designed to fulfill three overall objectives:



### Minimum Standards

Over the course of the five-year permit cycle, your community is required, at a minimum, to:

- reach 50 percent of its population with a targeted message,
- conduct at least five public involvement activities,
- develop an annual outreach strategy, and
- evaluate the effectiveness of individual activities and of the Public Involvement and Public Education program as a whole.



### Intent of the Permit

The intent of the municipal stormwater permit is to reduce water pollution from stormwater runoff in the community. This means that PIPE Program activities should ultimately lead to a voluntary change of behavior, from that which negatively impacts local water quality to behavior that has a positive impact. Cuyahoga SWCD identifies specific behaviors that impact stormwater quality and focuses on reducing barriers to changing these behaviors.



### Community Priorities

Each community has its own unique set of stormwater issues such as stream bank erosion, flooding and water quality. A community's Engineer, Service Department and elected officials are often highly aware of these issues, since residents bring them directly to their attention. Please let us know if there are specific issues or areas of your community that you would like to see addressed by the PIPE program.



# PIPE Program

Stormwater Public Involvement & Public Education in Your Community

## Cuyahoga SWCD PIPE Program Deliverables

Annual Outreach Strategy Document

Presentations to Community and School Groups

Mailing of Educational Materials to Target Audiences (10%/year)

Annual Outreach Poster for display in the Community

Stormwater Education Page on Cuyahoga SWCD web site

Print & Digital Materials for distribution via web and social media, and at Community Buildings

Backyard Conservation Workshops: Rain Barrels, Green Cleaning, Rain Gardens

Stream & Community Cleanups, Tree Planting Events, Conservation Pledges

Ohio EPA Reporting: Direct Entry of MCM 1&2 Activities in OEPA's STREAMS Reporting System

Community Support during OEPA Audits

# 2026-2030 PIPE PROGRAM ADMINISTRATION

■ - CUYAHOGA SWCD

■ - NEORSD

■ - MUNICIPALITY

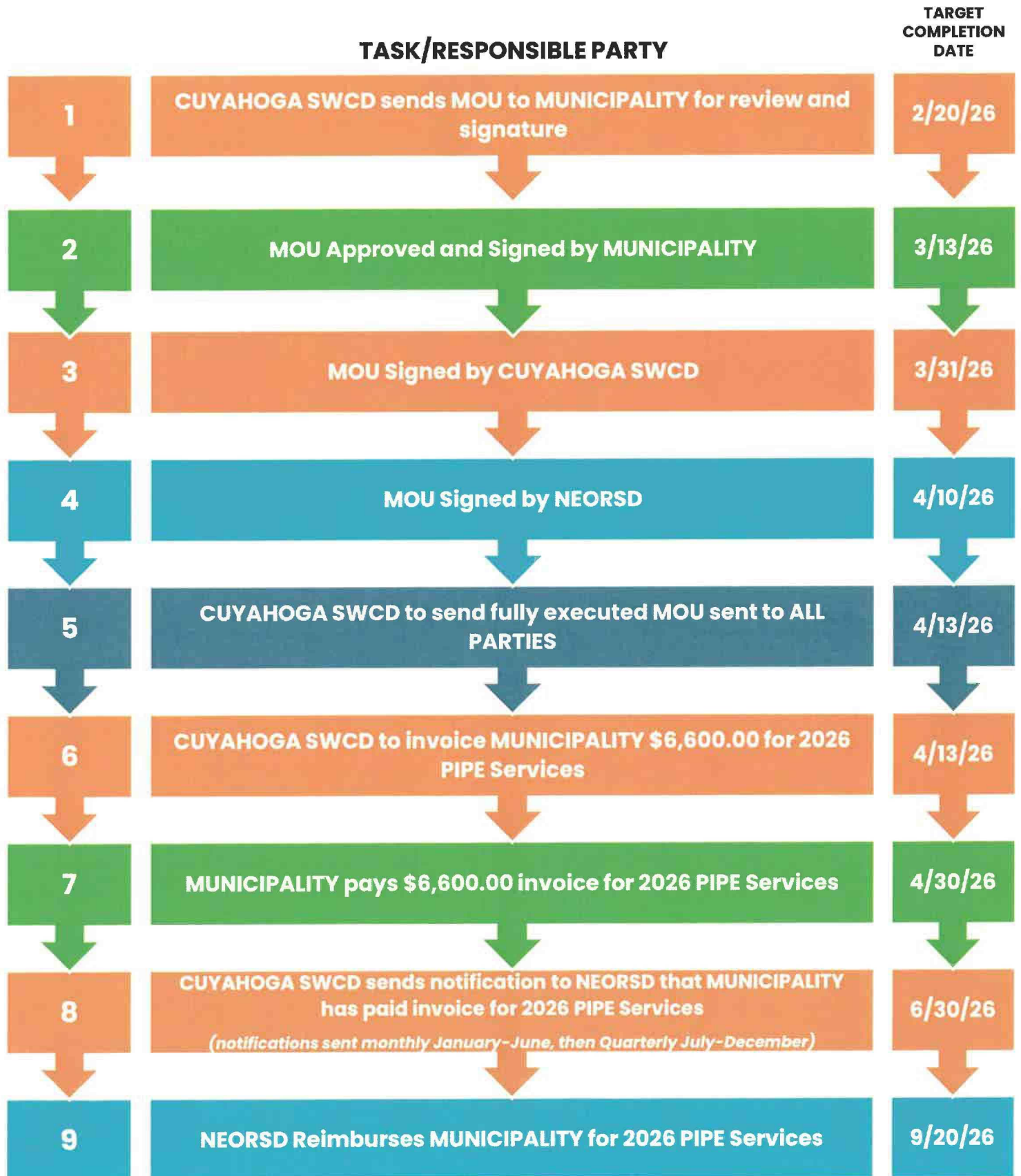

A RESOLUTION AUTHORIZING THE MAYOR TO ENTER INTO AN AGREEMENT WITH CLEVELAND FREIGHTLINER, INC. FOR THE PURCHASE OF ONE (1) WESTERN STAR 47X TRUCK CAB AND CHASSIS AND TO ENTER INTO AN AGREEMENT WITH CONCORD ROAD EQUIPMENT MFG., LLC FOR THE PURCHASE AND INSTALLATION OF ONE (1) STAINLESS STEEL DUMP BODY WITH SNOW AND ICE CONTROL PACKAGE FOR THE TRUCK; WAIVING COMPETITIVE BIDDING; AND DECLARING THIS TO BE AN URGENT MEASURE

WHEREAS, Council by Ordinance No. 1986-79 authorized the Mayor in lieu of competitive bidding by the City to enter into purchase orders with suppliers of products and/or services from a list prepared by the State of Ohio, after the State received competitively bid contracts with such suppliers in accordance with the State laws;

WHEREAS, the Public Works Director has recommended the purchase of one (1) Western Star 47X Truck Cab and Chassis from Valley Freightliner, Inc. and has recommended the purchase and installation of one (1) Stainless Steel Dump Body with Snow and Ice Control Package from Concord Road Equipment Mfg., LLC, for that truck as set forth in the two quotations supplied to this Council;

WHEREAS, the Valley Freightliner, Inc. price quotation to the City of \$139,692 is in accordance with ODOT Contract #023A26-9 and the Concord Road Equipment Mfg., LLC price quotation to the City of \$144,622.26 is in accordance with State Bid Contract Index # STS515;

WHEREAS, the purchase and installation amount for both the one (1) Truck Cab and Chassis and the one (1) Stainless-Steel Dump Body with Snow and Ice Control Package are for a total amount not to exceed Two Hundred Eighty-Four Thousand Three Hundred Fourteen Dollars and Forty-Six Cents (\$284,314,.46).

NOW, THEREFORE, BE IT RESOLVED, by the Council of the City of Beachwood, County of Cuyahoga, and State of Ohio that:

Section 1: Based upon the quotations received from Concord Road Equipment Mfg., LLC and from Valley Freightliner, Inc., the Mayor is authorized to purchase one (1) Truck Cab and Chassis and one (1) Stainless Steel Dump Body with a Snow and Ice Control Package in a total amount not to exceed Two Hundred Eighty-Four Thousand Three Hundred Fourteen Dollars and Forty-Six Cents (\$284,314,.46).

Section 2: It is found and determined that all formal actions and deliberations of Council and its committees relating to the passage of this legislation that resulted in formal action were in meetings open to the public where required by Chapter 105 of the Codified Ordinances of the City.

Section 3: This Resolution is declared to be an urgent measure necessary for the public peace, health, safety, or the efficient operation of the City; and for the further reason that it is necessary to have said equipment available for use at the earliest time to serve the public safety and welfare; wherefore, this Resolution shall be in full force and effect immediately upon its passage and approval by the Mayor.

Attest:

I hereby certify this legislation was duly adopted on the 9<sup>th</sup> day of March, 2026, and presented to the Mayor for approval or rejection in accordance with Article III, Section 8 of the Charter on the 10<sup>th</sup> day of March, 2026.

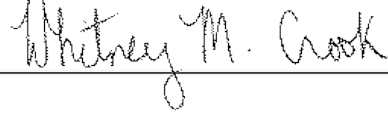

\_\_\_\_\_  
Clerk

Approval:

I have approved this legislation this 10<sup>th</sup> day of March, 2026 and filed it with the Clerk.



\_\_\_\_\_  
Mayor

**BEACHWOOD PUBLIC WORKS DEPARTMENT  
INTER-OFFICE MEMORANDUM**

**TO:** Mayor Justin Berns

**FROM:** Chris Arrietta, Public Works Director

**DATE:** February 23, 2026

**RE:** Council Agenda Item: Equipment Purchase – Salt Truck

---

Public Works is requesting approval to purchase one (1) Western Star 47X Cab and Chassis from Cleveland Freightliner and one (1) Dump Body with a Snow and Ice Control Package from Concord Road Equipment at a total cost of \$284,314.46.

This purchase will replace Unit #26, a 2001 IHC Dump Body, which is scheduled for replacement.

The Cab and Chassis will be acquired through the Ohio Department of Transportation State Contract (DOT023A26-9). The Snow and Ice Control Package will be purchased under the Ohio Department of Administrative Services Contract Schedule (#800925 - Index #STS515).

Please let me know if you have any questions regarding this request. Upon approval, I would like to include this item on the agenda for the next Council meeting.

**Prepared for:**  
BEACHWOOD CITY OF  
23355 Mercantile Rd  
Beachwood, OH 44122  
Phone: 2162921495

**Prepared by:**  
Greg Simonic  
CLEVELAND FREIGHTLINER, INC.  
10901 Brookpark Rd  
Parma, OH 44130  
Phone: 216-267-4800

*A proposal for*  
**BEACHWOOD CITY OF**

*Prepared by*  
**CLEVELAND FREIGHTLINER, INC.**  
*Greg Simonic*

*Dec 31, 2025*

**Western Star 47X**

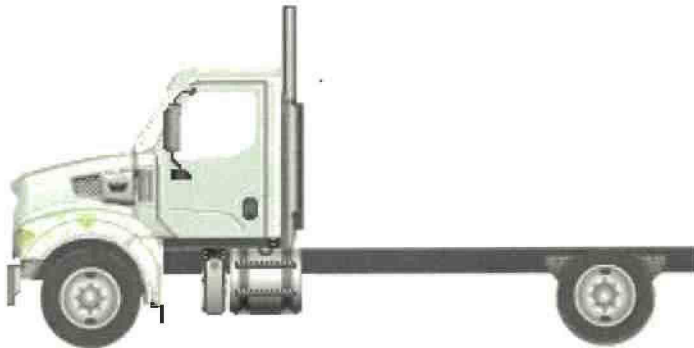

Components shown may not reflect all spec'd options and are not to scale

Application Version 12.0.703  
Data Version PRL-30X.018  
WSTR 47X ODOT 023A-26  
BEACHWOOD

12/31/2025 9:35 AM

Page 1 of 18

Prepared for:  
 BEACHWOOD CITY OF  
 23355 Mercantile Rd  
 Beachwood, OH 44122  
 Phone: 2162921495

Prepared by:  
 Greg Simonic  
 CLEVELAND FREIGHTLINER, INC.  
 10901 Brookpark Rd  
 Parma, OH 44130  
 Phone: 216-267-4800

## S P E C I F I C A T I O N   P R O P O S A L

Data Code	Description	Weight Front	Weight Rear
<b>Price Level</b>			
PRL-30X	47X/49X PRL-30X (EFF:MY27 ORDERS)		
<b>Data Version</b>			
DRL-018	SPECPRO21 DATA RELEASE VER 018		
<b>Vehicle Configuration</b>			
001-470	WESTERN STAR 47X	9,050	6,525
004-227	2027 MODEL YEAR SPECIFIED		
002-003	SET FORWARD AXLE - TRUCK	-480	480
019-006	TRAILER TOWING PROVISION AT END OF FRAME WITH SAE J560	10	10
003-001	LH PRIMARY STEERING LOCATION		
<b>General Service</b>			
AA1-003	TRUCK/TRAILER CONFIGURATION		
AA6-002	DOMICILED, USA 50 STATES (EPA CLEAN IDLE LABEL OR NO CLEAN IDLE REQUIRED)		
99D-027	EPA CLEAN IDLE LABEL - (INCLUDES 6X4 INCH LABEL ON LOWER FORWARD OF DRIVER DOOR)		
A85-010	UTILITY/REPAIR/MAINTENANCE SERVICE		
A84-1GM	GOVERNMENT BUSINESS SEGMENT		
AA4-010	DIRT/SAND/ROCK COMMODITY		
AA5-002	TERRAIN/DUTY: 100% (ALL) OF THE TIME, IN TRANSIT, IS SPENT ON PAVED ROADS		
AB1-008	MAXIMUM 8% EXPECTED GRADE		
AB5-001	SMOOTH CONCRETE OR ASPHALT PAVEMENT - MOST SEVERE IN-TRANSIT (BETWEEN SITES) ROAD SURFACE		
995-1A5	WESTERN STAR VOCATIONAL WARRANTY		
A66-99D	EXPECTED FRONT AXLE(S) LOAD : 20000.0 lbs		
A68-99D	EXPECTED REAR DRIVE AXLE(S) LOAD : 24020.0 lbs		
A63-99D	EXPECTED GROSS VEHICLE WEIGHT CAPACITY : 44020.0 lbs		
A70-99D	EXPECTED GROSS COMBINATION WEIGHT : 80000.0 lbs		
<b>Truck Service</b>			

Application Version 12.0.703  
 Data Version PRL-30X.018  
 WSTR 47X ODOT 023A-26  
 BEACHWOOD

12/31/2025 9:35 AM

Page 2 of 18

Prepared for:  
 BEACHWOOD CITY OF  
 23355 Mercantile Rd  
 Beachwood, OH 44122  
 Phone: 2162921495

Prepared by:  
 Greg Simonic  
 CLEVELAND FREIGHTLINER, INC.  
 10901 Brookpark Rd  
 Parma, OH 44130  
 Phone: 216-267-4800

Data Code	Description	Weight Front	Weight Rear
AA3-018	FRONT PLOW/END DUMP BODY		
AF3-1N7	CONCORD ROAD EQUIPMENT		
<b>Engine</b>			
101-3BR	CUM L9 360 HP @ 2200 RPM; 2200 GOV RPM, 1150 LB-FT @ 1200 RPM	-850	-70
<b>Electronic Parameters</b>			
79A-065	65 MPH ROAD SPEED LIMIT		
79K-016	PTO MODE ENGINE RPM LIMIT - 2000 RPM		
79P-005	PTO RPM WITH CRUISE SET SWITCH - 1000 RPM		
79U-004	PTO GOVERNOR RAMP RATE - 100 RPM PER SECOND		
79V-001	FUEL DOSING OF AFTERTREATMENT ENABLED IN PTO MODE-CLEANS HYDROCARBONS AT HIGH TEMPERATURES ONLY		
79W-024	CRUISE CONTROL BUTTON PTO CONTROL		
79X-005	PTO SPEED 1 SETTING - 900 RPM		
80G-015	PTO MINIMUM RPM - 800		
80J-001	REGEN INHIBIT SPEED THRESHOLD - 0 MPH		
80S-004	PTO 1, DASH SWITCH, ENGAGE WHILE DRIVING		
<b>Engine Equipment</b>			
99C-024	EPA 2010/GHG 2024 CONFIGURATION		
13E-001	STANDARD OIL PAN		
105-001	ENGINE MOUNTED OIL CHECK AND FILL		
014-111	SIDE OF HOOD AIR INTAKE WITH ENGINE MOUNTED AIR CLEANER, WITH INSIDE/OUTSIDE AIR AND SNOW DOOR		
124-1E1	DR 12V 200 AMP 28-SI QUADRAMOUNT PAD ALTERNATOR WITH REMOTE BATTERY VOLT SENSE	-10	
292-222	(3) DTNA GENUINE, HIGH TEMP AGM STARTING AND CYCLING, MIN 2775CCA, 570RC, THREADED STUD BATTERIES		
290-1AC	PASSENGER SEAT BATTERY BOX VENTED TO OUTSIDE OF CAB		
282-013	BATTERY BOX MOUNTED UNDER PASSENGER SEAT		
291-017	WIRE GROUND RETURN FOR BATTERY CABLES WITH ADDITIONAL FRAME GROUND RETURN		
289-006	PLASTIC BATTERY BOX COVER		
33M-001	AUXILIARY POWER NET DISTRIBUTION BLOCK FOR BODY BUILDER USE	10	
293-058	NON-ESSENTIAL POSITIVE LOAD DISCONNECT, IN CAB CONTROL SWITCH MOUNTED OUTBOARD OF DRIVER SEAT	2	

Prepared for:  
 BEACHWOOD CITY OF  
 23355 Mercantile Rd  
 Beachwood, OH 44122  
 Phone: 2162921495

Prepared by:  
 Greg Simonic  
 CLEVELAND FREIGHTLINER, INC.  
 10901 Brookpark Rd  
 Parma, OH 44130  
 Phone: 216-267-4800

Data Code	Description	Weight Front	Weight Rear
107-032	CUMMINS TURBOCHARGED 18.7 CFM AIR COMPRESSOR WITH INTERNAL SAFETY VALVE		
152-041	ELECTRONIC ENGINE INTEGRAL SHUTDOWN PROTECTION SYSTEM		
128-1AR	CUMMINS ENGINE INTEGRAL BRAKE WITH VARIABLE GEOMETRY TURBO ON/OFF WITH BRAKE LAMPS	20	
016-1C2	RH OUTBOARD UNDER STEP MOUNTED HORIZONTAL AFTERTREATMENT SYSTEM ASSEMBLY WITH RH B-PILLAR MOUNTED VERTICAL TAILPIPE		
28F-015	ENGINE AFTERTREATMENT DEVICE, AUTOMATIC OVER THE ROAD ACTIVE REGENERATION AND VIRTUAL REGENERATION REQUEST SWITCH IN CLUSTER AND DASH MOUNTED INHIBIT SWITCH		
239-038	11 FOOT 06 INCH (138 INCH+0/-5.9 INCH) EXHAUST SYSTEM HEIGHT		
233-017	STANDARD CURVE BRIGHT UPPER STACK(S)		
237-1CR	RH CURVED VERTICAL TAILPIPE B-PILLAR MOUNTED ROUTED FROM STEP		
23U-027	8 GALLON DIESEL EXHAUST FLUID TANK		
23Z-005	UNPOLISHED ALUMINUM WST DIESEL EXHAUST FLUID TANK COVER		
43X-001	LH HEAVY DUTY STANDARD DIESEL EXHAUST FLUID TANK LOCATION		
43Y-001	STANDARD DIESEL EXHAUST FLUID TANK CAP		
242-049	PERFORATED SINGLE STAINLESS STEEL MUFFLER/TAIPIPE SHIELD WITH WESTERN STAR LOGO		
273-059	ELECTRONICALLY CONTROLLED VARIABLE SPEED VISCOUS FAN DRIVE		
276-001	AUTOMATIC FAN CONTROL WITHOUT DASH SWITCH, NON ENGINE MOUNTED		
122-1H4	DETROIT FUEL/WATER SEPARATOR WITH WATER IN FUEL SENSOR AND 12 VOLT PREHEATER	10	
110-003	CUMMINS SPIN ON FUEL FILTER		
118-001	FULL FLOW OIL FILTER		
266-107	1400 SQUARE INCH VOCATIONAL RADIATOR		
103-039	ANTIFREEZE TO -34F, OAT (NITRITE AND SILICATE FREE) EXTENDED LIFE COOLANT		
171-007	GATES BLUE STRIPE COOLANT HOSES OR EQUIVALENT		
261-001	STANDARD CHARGE AIR COOLER PLUMBING		
270-016	RADIATOR DRAIN VALVE		
168-002	LOWER RADIATOR GUARD		
132-004	ELECTRIC GRID AIR INTAKE WARMER		

Prepared for:  
 BEACHWOOD CITY OF  
 23355 Mercantile Rd  
 Beachwood, OH 44122  
 Phone: 2162921495

Prepared by:  
 Greg Simonic  
 CLEVELAND FREIGHTLINER, INC.  
 10901 Brookpark Rd  
 Parma, OH 44130  
 Phone: 216-267-4800

Data Code	Description	Weight Front	Weight Rear
155-055	DELCO 12V 39MT HD/OCP STARTER WITH THERMAL PROTECTION AND INTEGRATED MAGNETIC SWITCH	-45	

**Transmission**

342-582	ALLISON 3000 RDS AUTOMATIC TRANSMISSION WITH PTO PROVISION	-230	-130
---------	--	------	------

**Transmission Equipment**

343-339	ALLISON VOCATIONAL PACKAGE 223 - AVAILABLE ON 3000/4000 PRODUCT FAMILIES WITH VOCATIONAL MODELS RDS, HS, MH AND TRV		
84B-012	ALLISON VOCATIONAL RATING FOR ON/OFF HIGHWAY APPLICATIONS AVAILABLE WITH ALL PRODUCT FAMILIES		
84C-023	PRIMARY MODE GEARS, LOWEST GEAR 1, START GEAR 1, HIGHEST GEAR 6, AVAILABLE FOR 3000/4000 PRODUCT FAMILIES ONLY		
84D-023	SECONDARY MODE GEARS, LOWEST GEAR 1, START GEAR 1, HIGHEST GEAR 6, AVAILABLE FOR 3000/4000 PRODUCT FAMILIES ONLY		
84E-017	S5 PERFORMANCE LIMITING PRIMARY SHIFT SCHEDULE, AVAILABLE FOR 3000/4000 PRODUCT FAMILIES ONLY		
84F-016	S5 PERFORMANCE LIMITING SECONDARY SHIFT SCHEDULE, AVAILABLE FOR 3000/4000 PRODUCT FAMILIES ONLY		
84G-013	2100 RPM PRIMARY MODE SHIFT SPEED		
84H-013	2100 RPM SECONDARY MODE SHIFT SPEED		
85E-011	MAXIMUM ENGINE SPEED FOR PTO ENGAGEMENT 1000 RPM		
353-074	QUICKFIT BODY LIGHTING CONNECTOR UNDER CAB, WITH BLUNTCUTS		
34C-011	ELECTRONIC TRANSMISSION WIRING TO CUSTOMER INTERFACE CONNECTOR		
362-2JT	CUSTOMER INSTALLED CHELSEA 281 SERIES PTO		
363-001	PTO MOUNTING, LH SIDE OF MAIN TRANSMISSION ALLISON		
341-018	MAGNETIC PLUGS, ENGINE DRAIN, TRANSMISSION DRAIN, AXLE(S) FILL AND DRAIN		
345-003	PUSH BUTTON ELECTRONIC SHIFT CONTROL, DASH MOUNTED		
370-006	WATER TO OIL TRANSMISSION COOLER		
346-003	TRANSMISSION OIL CHECK AND FILL WITH ELECTRONIC OIL LEVEL CHECK		
35T-001	ATF-SYNTHETIC AUTOMATIC TRANSMISSION FLUID		

Prepared for:  
 BEACHWOOD CITY OF  
 23355 Mercantile Rd  
 Beachwood, OH 44122  
 Phone: 2162921495

Prepared by:  
 Greg Simonic  
 CLEVELAND FREIGHTLINER, INC.  
 10901 Brookpark Rd  
 Parma, OH 44130  
 Phone: 216-267-4800

Data Code	Description	Weight Front	Weight Rear
<b>Front Axle and Equipment</b>			
400-1BB	DETROIT DA-F-20.0-5 20,000# FL1 71.0 KPI/3.74 DROP SINGLE FRONT AXLE	190	
418-060	CONMET PRESET PLUS PREMIUM IRON FRONT HUBS	20	
402-030	MERITOR 16.5X6 Q+ CAST SPIDER CAM FRONT BRAKES, DOUBLE ANCHOR, FABRICATED SHOES	10	
403-002	NON-ASBESTOS FRONT BRAKE LINING		
419-023	CONMET CAST IRON FRONT BRAKE DRUMS		
427-001	FRONT BRAKE DUST SHIELDS	5	
409-006	FRONT OIL SEALS		
408-001	VENTED FRONT HUB CAPS WITH WINDOW, CENTER AND SIDE PLUGS - OIL		
405-002	MERITOR AUTOMATIC FRONT SLACK ADJUSTERS		
536-104	DUAL POWER STEERING GEARS, BENDIX 16- 20K	80	
534-003	4 QUART POWER STEERING RESERVOIR	5	
533-001	OIL/AIR POWER STEERING COOLER	5	
40T-002	CURRENT AVAILABLE SYNTHETIC 75W-90 FRONT AXLE LUBE		
<b>Front Suspension</b>			
620-006	20,000# FLAT LEAF FRONT SUSPENSION	250	
619-002	THREADED SPRING PINS AND BUSHINGS - FRONT SUSPENSION		
410-001	FRONT SHOCK ABSORBERS		
<b>Rear Axle and Equipment</b>			
N	420-022	MERITOR RS-26-185 26,000# T-SERIES SINGLE REAR AXLE	-425
	450-060	CONMET PRESET PLUS PREMIUM IRON REAR HUBS	30
	421-563	5.63 REAR AXLE RATIO	
	424-001	IRON REAR AXLE CARRIER WITH STANDARD AXLE HOUSING	
	386-073	MXL 17T MERITOR EXTENDED LUBE MAIN DRIVELINE WITH HALF ROUND YOKES	-60
	388-998	NO INTERAXLE (#3) DRIVELINE	
	452-001	DRIVER CONTROLLED TRACTION DIFFERENTIAL - SINGLE REAR AXLE	20
	878-018	(1) DRIVER CONTROLLED DIFFERENTIAL LOCK REAR VALVE FOR SINGLE DRIVE AXLE	
	87B-008	INDICATOR LIGHT FOR EACH DIFFERENTIAL LOCKOUT SWITCH	

Prepared for:  
 BEACHWOOD CITY OF  
 23355 Mercantile Rd  
 Beachwood, OH 44122  
 Phone: 2162921495

Prepared by:  
 Greg Simonic  
 CLEVELAND FREIGHTLINER, INC.  
 10901 Brookpark Rd  
 Parma, OH 44130  
 Phone: 216-267-4800

Data Code	Description	Weight Front	Weight Rear
423-039	MERITOR 16.5X7 Q+ CAST SPIDER CAM REAR BRAKES, DOUBLE ANCHOR HEAVY DUTY BRAKE AND SHOES		40
433-002	NON-ASBESTOS REAR BRAKE LINING		
434-011	BRAKE CAMS AND CHAMBERS ON FORWARD SIDE OF DRIVE AXLE(S)		
451-023	CONMET CAST IRON REAR BRAKE DRUMS		
425-002	REAR BRAKE DUST SHIELDS		5
440-006	REAR OIL SEALS		
426-100	WABCO TRISTOP D LONGSTROKE 1-DRIVE AXLE SPRING PARKING CHAMBERS		-20
428-003	HALDEX AUTOMATIC REAR SLACK ADJUSTERS		
41T-002	CURRENT AVAILABLE SYNTHETIC 75W-90 REAR AXLE LUBE		
42T-001	STANDARD REAR AXLE BREATHER(S)		
<b>Rear Suspension</b>			
N	622-1DF	30,000# FLAT LEAF SPRING REAR SUSPENSION WITH HELPER AND RADIUS ROD	200
	621-108	9.5 INCH NOMINAL RIDE HEIGHT (460MM GLOBAL REFERENCE HEIGHT)	
	431-001	STANDARD AXLE SEATS IN AXLE CLAMP GROUP	
	623-005	FORE/AFT CONTROL RODS	
	439-998	NO REAR SHOCK ABSORBERS	-30
<b>Pusher / Tag Equipment</b>			
	429-998	NO PUSHER/TAG BRAKE DUST SHIELDS	
<b>Brake System</b>			
	490-1AU	WABCO 4S/4M ABS WITH TRACTION CONTROL WITH ATC SHUT OFF SWITCH	
	871-001	REINFORCED NYLON, FABRIC BRAID AND WIRE BRAID CHASSIS AIR LINES	
	46E-001	STANDARD AIR MANAGEMENT UNIT	
	432-003	RELAY VALVE WITH 5-8 PSI CRACK PRESSURE, NO REAR PROPORTIONING VALVE	
	480-088	WABCO SYSTEM SAVER HP WITH INTEGRAL AIR GOVERNOR AND HEATER	
	483-004	WABCO OIL COALESCING FILTER FOR AIR DRYER	
	479-005	AIR DRYER MOUNTED INBOARD ON RH RAIL	
	460-019	ALUMINUM AIR BRAKE RESERVOIRS MOUNTED INSIDE RAILS	-10 -15
	477-019	BW DV-2 AUTO DRAIN VALVE WITH HEATER TO WET TANK; DRAIN VALVE CABLES ON ALL OTHER TANKS	

**Trailer Connections**

Application Version 12.0.703  
 Data Version PRL-30X.018  
 WSTR 47X ODOT 023A-26  
 BEACHWOOD

12/31/2025 9:35 AM

Page 7 of 18

Prepared for:  
 BEACHWOOD CITY OF  
 23355 Mercantile Rd  
 Beachwood, OH 44122  
 Phone: 2162921495

Prepared by:  
 Greg Simonic  
 CLEVELAND FREIGHTLINER, INC.  
 10901 Brookpark Rd  
 Parma, OH 44130  
 Phone: 216-267-4800

Data Code	Description	Weight Front	Weight Rear
914-025	AIR CONNECTIONS TO END OF FRAME WITH GLAD HANDS FOR TRUCK AND DUST COVERS		
296-010	PRIMARY CONNECTOR/RECEPTACLE WIRED FOR SEPARATE STOP/TURN, ABS CENTER PIN POWERED THROUGH IGNITION		
303-026	SAE J560 7-WAY PRIMARY TRAILER CABLE RECEPTACLE TEMPORARY TIED & COILED IN CHASSIS END OF FRAME WITH 2' ADDITIONAL; NO BRACKETS		
310-998	NO TRAILER ELECTRICAL CABLE	-10	
<b>Wheelbase &amp; Frame</b>			
545-089	4240MM (167 INCH) WHEELBASE, SFA ONLY		
546-106	13.0MM X 87.0MM X 311.0MM STEEL FRAME (0.51X3.43X12.24 INCH) 120 KSI	-110	460
552-037	1775MM (70 INCH) REAR FRAME OVERHANG		
55W-006	FRAME OVERHANG RANGE: 61 INCH TO 70 INCH	-30	90
549-044	20 INCH INTEGRAL FRONT FRAME EXTENSION	100	
AC8-99D	CALC'D BACK OF CAB TO REAR SUSP C/L (CA) : 85.43 in		
AE4-99D	CALC'D FRAME LENGTH - OVERALL : 285.43 in		
ZF1-99D	FRAME HEIGHT TOP FRONT UNLADEN : 45.29 in		
ZF2-99D	FRAME HEIGHT TOP FRONT LADEN : 41.1 in		
ZF3-99D	FRAME HEIGHT TOP REAR UNLADEN : 43.85 in		
ZF4-99D	FRAME HEIGHT TOP REAR LADEN : 40.88 in		
553-001	SQUARE END OF FRAME		
559-001	STANDARD WEIGHT ENGINE CROSSMEMBER		
561-015	STANDARD CAST ALUMINUM CROSSMEMBER BACK OF TRANSMISSION	-15	
562-063	STANDARD CAST ALUMINUM MIDSHIP		
572-078	HEAVY DUTY REAR C-CHANNEL CROSSMEMBER, NON-TOWING		70
565-001	STANDARD SUSPENSION CROSSMEMBER		20
568-001	STANDARD WEIGHT REAR SUSPENSION CROSSMEMBER		
<b>Chassis Equipment</b>			
025-001	UNPOLISHED ALUMINUM WST EQUIPMENT COVERS		
556-997	OMIT FRONT BUMPER, CUSTOMER INSTALLED SPECIAL BUMPER, DOES NOT COMPLY WITH FMCSR 393.203	-60	
586-015	FRONT ANTI-SPRAY CAB MOUNTED MUDFLAPS		
558-998	NO FRONT TOW HOOKS	-15	
574-998	NO LICENSE PLATE MOUNTING		
551-034	CLASS 10.9 THREADED METRIC FASTENERS		

Prepared for:  
 BEACHWOOD CITY OF  
 23355 Mercantile Rd  
 Beachwood, OH 44122  
 Phone: 2162921495

Prepared by:  
 Greg Simonic  
 CLEVELAND FREIGHTLINER, INC.  
 10901 Brookpark Rd  
 Parma, OH 44130  
 Phone: 216-267-4800

Data Code	Description	Weight Front	Weight Rear
44Z-005	EXTERIOR HARNESSES WRAPPED IN ABRASION TAPE, SECONDARY COVERING, & CONNECTOR PROTECTION		
* 601-020	3D STEP VEHICLE MODEL mdavis@concordroadequipment.com		
<b>Fuel Tanks</b>			
204-152	70 GALLON/264 LITER ALUMINUM FUEL TANK - LH	-30	-10
218-006	25 INCH DIAMETER FUEL TANK(S)		
215-007	PLAIN ALUMINUM/PAINTED STEEL FUEL/HYDRAULIC TANK(S) WITH POLISHED STAINLESS STEEL BANDS		
212-007	FUEL TANK(S) FORWARD		
664-001	PLAIN STEP FINISH		
205-002	CHROME FUEL TANK CAP(S)		
216-020	EQUIFLO INBOARD FUEL SYSTEM		
202-016	HIGH TEMPERATURE REINFORCED NYLON FUEL LINE		
<b>Tires</b>			
093-1YU	CONTINENTAL HAU 3 WT 315/80R22.5 20 PLY RADIAL FRONT TIRES	100	
094-18X	CONTINENTAL HDL3EP 11R22.5 14 PLY RADIAL REAR TIRES		48
<b>Wheels</b>			
502-664	ALCOA ULTRA ONE 89U63X 22.5X9.00 10-HUB PILOT 3.12 INSET 10-HD ALUMINUM FRONT WHEELS	-44	
505-1HB	ALCOA 88167X 22.5X8.25 10-HUB PILOT ALUMINUM DISC REAR WHEELS		-124
496-011	FRONT WHEEL MOUNTING NUTS		
497-011	REAR WHEEL MOUNTING NUTS		
<b>Cab Exterior</b>			
829-053	111.6 INCH BBC CONVENTIONAL ALUMINUM CAB		
82A-028	STAINLESS STEEL CAB ACCENT MOLDING		
667-001	FRONT FENDERS		
754-017	BOLT-ON MOLDED FLEXIBLE FENDER EXTENSIONS	10	
678-066	INTERIOR GRAB HANDLES WITH ADDED LOWER LH AND RH A PILLAR GRAB HANDLES AND LH AND RH EXTERIOR NON-SLIP GRAB HANDLES		
65X-010	BRIGHT HOOD MOUNTED AIR INTAKE GRILLE, BLACK SCREEN, WITH LED ACCENT LIGHTS		
640-016	X-SERIES STEEL REINFORCED ALUMINUM CAB		

Prepared for:  
 BEACHWOOD CITY OF  
 23355 Mercantile Rd  
 Beachwood, OH 44122  
 Phone: 2162921495

Prepared by:  
 Greg Simonic  
 CLEVELAND FREIGHTLINER, INC.  
 10901 Brookpark Rd  
 Parma, OH 44130  
 Phone: 216-267-4800

Data Code	Description	Weight Front	Weight Rear
644-048	X-SERIES VOCATIONAL HOOD		
67U-001	HOOD OPENING ASSIST WITH LOCKING STRUT		
652-016	WESTERN STAR NAMEPLATES		
727-1AY	SINGLE AIR HORN UNDER LH DECK	-4	
726-001	SINGLE ELECTRIC HORN		
575-001	REAR LICENSE PLATE MOUNT END OF FRAME		
650-008	AIR CAB MOUNTING		
312-095	DUAL STAGE INTELLIGENT LED HEADLIGHTS WITH HEATED LENS SYSTEM		
302-073	VISOR MOUNTED LED MARKER LIGHTS		
314-823	WIRING AND SWITCH FOR CUSTOMER FURNISHED SNOW PLOW LAMPS WITH SINGLE CONNECTION AT LH FORWARD		
311-001	DAYTIME RUNNING LIGHTS		
294-1AY	INTEGRAL LED STOP/TAIL/BACKUP LIGHTS		
300-043	LED SIDE TURN SIGNAL		
744-106	C-BAR MIRROR SYSTEM WITH DUAL HEATED MIRRORS WITH INTEGRAL HEATED CONVEX, DUAL REMOTE, STAINLESS STEEL BACK COVER, AND BLACK C-BAR		
796-001	102 INCH EQUIPMENT WIDTH		
743-209	LH AND RH CONVEX MIRRORS INTEGRAL WITH PRIMARY MIRRORS		
74A-001	RH DOWN VIEW MIRROR		
74B-113	RH AND LH HEATED BLACK HOOD/FENDER MOUNTED SIDE VIEW MIRRORS WITH BLACK MOUNTING ARM	8	
729-001	STANDARD SIDE/REAR REFLECTORS		
677-098	UNPOLISHED ALUMINUM WST AFTERTREATMENT SYSTEM COVER		
776-998	NO SLEEPER VENT	-10	
764-020	STAINLESS STEEL EXTERIOR SUN VISOR WITH INTEGRAL MARKER LIGHTS	16	
768-064	SINGLE SOLAR TINTED REAR WINDOW, (1) 31 INCH X 20 INCH	-10	
663-032	1-PIECE ROPED-IN HEATED WINDSHIELD		
659-006	8 LITER (2 GAL) WINDSHIELD WASHER RESERVOIR, CAB MOUNTED, WITH FLUID LEVEL INDICATOR		

### Cab Interior

055-015	X-SERIES BASE INTERIOR TRIM LEVEL PACKAGE
707-1C3	CHARCOAL BLACK VINYL BASE LEVEL INTERIOR
70K-016	CARBON WITH BASE BLACK ACCENT
772-001	BLACK MATS

Application Version 12.0.703  
 Data Version PRL-30X.018  
 WSTR 47X ODOT 023A-26  
 BEACHWOOD

12/31/2025 9:35 AM

Page 10 of 18

Prepared for:  
 BEACHWOOD CITY OF  
 23355 Mercantile Rd  
 Beachwood, OH 44122  
 Phone: 2162921495

Prepared by:  
 Greg Simonic  
 CLEVELAND FREIGHTLINER, INC.  
 10901 Brookpark Rd  
 Parma, OH 44130  
 Phone: 216-267-4800

Data Code	Description	Weight Front	Weight Rear
785-014	(2) DASH MOUNTED POWER OUTLETS AND COIN TRAY		
691-001	FORWARD ROOF MOUNTED CONSOLE		
693-019	LH AND RH DOOR STORAGE POCKETS INTEGRATED INTO MOLDED DOOR PANELS		
741-015	(2) COAT HOOKS ON BACKWALL OF CAB		
745-998	NO UPPER BUNK	-50	-50
738-021	DIGITAL ALARM CLOCK IN DRIVER DISPLAY		
170-015	STANDARD HEATER PLUMBING		
698-001	RADIATOR MOUNTED AIR CONDITIONER CONDENSER		
739-034	PREMIUM INSULATION		
324-1B2	PREMIUM LED CAB LIGHTING		
787-998	NO SECURITY DEVICE		
657-145	ALL UNIT (S) KEYED ALIKE WITH CUSTOMER SPECIFIED KEY NUMBER FT1089		
78G-004	KEY QUANTITY OF 4		
655-028	LH AND RH ELECTRIC DOOR LOCKS WITH AUTO UNLOCK FEATURE WHEN DOOR IS SET FROM OPEN TO CLOSED POSITION		
64C-003	BLACK DOOR HANDLES		
740-998	NO MATTRESS	-20	-15
756-1J6	PREMIUM 2.0 HIGH BACK AIR SUSPENSION DRIVER SEAT WITH 2 AIR LUMBAR, INTEGRATED CUSHION EXTENSION, TILT AND ADJUSTABLE SHOCK	20	
760-294	BATTERY BOX MID BACK NON SUSPENSION PASSENGER SEAT		
759-007	DUAL DRIVER SEAT ARMRESTS, NO PASSENGER SEAT ARMRESTS		
758-014	BLACK CORDURA PLUS CLOTH DRIVER SEAT COVER		
761-138	BLACK MORDURA CLOTH PASSENGER SEAT COVER WITH NO LOGO		
763-1AA	3 POINT ADJUSTABLE D-RING RETRACTOR DRIVER AND FIXED D-RING RETRACTOR PASSENGER SEAT BELTS		
532-002	ADJUSTABLE TILT AND TELESCOPING STEERING COLUMN		
540-044	4-SPOKE 18 INCH (450MM) BLACK STEERING WHEEL WITH SWITCHES		
765-002	DRIVER AND PASSENGER INTERIOR SUN VISORS		

### Instruments & Controls

185-004	STANDARD FOOT PEDAL SYSTEM
106-002	ELECTRONIC ACCELERATOR CONTROL

Prepared for:  
 BEACHWOOD CITY OF  
 23355 Mercantile Rd  
 Beachwood, OH 44122  
 Phone: 2162921495

Prepared by:  
 Greg Simonic  
 CLEVELAND FREIGHTLINER, INC.  
 10901 Brookpark Rd  
 Parma, OH 44130  
 Phone: 216-267-4800

Data Code	Description	Weight Front	Weight Rear
87L-003	ENGINE PTO SPEED CONTROL WITH PARK BRAKE AND NEUTRAL INTERLOCKS		
870-001	BLACK GAUGE BEZELS		
734-018	STANDARD CENTER INSTRUMENT PANEL		
840-001	DUAL NEEDLE PRIMARY AND SECONDARY AIR PRESSURE GAUGE		
198-025	INTAKE MOUNTED AIR RESTRICTION INDICATOR WITHOUT GRADUATIONS		
721-021	87 DB TO 112 DB SELF-ADJUSTING BACKUP ALARM		3
149-015	ELECTRONIC CRUISE CONTROL WITH CONTROLS ON STEERING WHEEL SPOKES		
156-007	KEY OPERATED IGNITION SWITCH AND INTEGRAL START POSITION; 4 POSITION OFF/RUN/START/ACCESSORY		
811-044	PREMIUM INSTRUMENT CLUSTER WITH 5.0 INCH TFT COLOR DISPLAY		
81B-003	DIGITAL PANEL LAMP DIMMER SWITCH IN DRIVER DISPLAY		
160-045	HEAVY DUTY ONBOARD DIAGNOSTICS INTERFACE CONNECTOR WITH DUST CAP LOCATED BELOW LH DASH		
844-001	2 INCH ELECTRIC FUEL GAUGE		
148-072	ENGINE REMOTE INTERFACE WITH ONE OR MORE SET SPEEDS		
856-001	ELECTRICAL ENGINE COOLANT TEMPERATURE GAUGE		
854-998	NO ENGINE OIL TEMPERATURE GAUGE		
852-002	ELECTRIC ENGINE OIL PRESSURE GAUGE		
864-001	2 INCH TRANSMISSION OIL TEMPERATURE GAUGE		
867-004	ELECTRONIC OUTSIDE TEMPERATURE SENSOR DISPLAY IN DRIVER MESSAGE CENTER		
830-017	ENGINE AND TRIP HOUR METERS INTEGRAL WITHIN DRIVER DISPLAY		
372-123	PTO CONTROLS FOR ENHANCED VEHICLE ELECTRIC/ELECTRONIC ARCHITECTURE		
736-998	NO OBSTACLE DETECTION SYSTEM		
73K-998	NO SIDE OBJECT DETECTION SYSTEM		
72J-998	NO DR ASSIST SYSTEM		
49B-998	NO VEHICLE STABILITY ADVISOR OR CONTROL		
73B-998	NO LANE DEPARTURE WARNING SYSTEM		
73H-014	(1) BACKUP CAMERA-END OF FRAME MOUNTED WITH 15 FOOT EXTRA LONG CABLE COILED AT END OF FRAME		

Prepared for:  
 BEACHWOOD CITY OF  
 23355 Mercantile Rd  
 Beachwood, OH 44122  
 Phone: 2162921495

Prepared by:  
 Greg Simonic  
 CLEVELAND FREIGHTLINER, INC.  
 10901 Brookpark Rd  
 Parma, OH 44130  
 Phone: 216-267-4800

Data Code	Description	Weight Front	Weight Rear
786-113	GENERIC TELEMATICS PREWIRE (CONSTANT BATTERY POWER/IGNITION/GROUND/J1939); RP1226 TYPE CONNECTOR AT PASSENGER SIDE OF DASH END		
6TS-005	TMC RP1226 ACCESSORY CONNECTOR LOCATED BEHIND PASSENGER SIDE REMOVEABLE DASH PANEL		
746-143	7" B-PANEL INTERACTIVE TOUCHSCREEN DISPLAY RADIO W/ USB-C, APPLE CARPLAY, ANDROID AUTO, BLUETOOTH/AM/FM/SXM/WB, WITH MICROPHONE		
747-001	DASH MOUNTED RADIO		
750-041	STANDARD SPEAKER SYSTEM		
753-998	NO AM/FM RADIO ANTENNA		
748-006	POWER AND GROUND WIRING PROVISION OVERHEAD		
749-001	ROOF/OVERHEAD CONSOLE CB RADIO PROVISION		
751-001	SINGLE REMOTE SPEAKER WITH LEAD FOR 2-WAY RADIO		
752-004	SINGLE FIBERGLASS LH MIRROR MOUNTED CB ANTENNA WITH BRACKET AND LEAD		
75W-001	HEADLINER MULTI-BAND ANTENNA: AM/FM/WEATHERBAND, WIF/BLUETOOTH, GNSS/GPS		
78C-003	INTEROPERABLE SDAR ANTENNA		
810-027	ELECTRONIC MPH SPEEDOMETER WITH SECONDARY KPH SCALE, WITHOUT ODOMETER		
812-032	ELECTRONIC 2500 RPM TACHOMETER		
813-1C8	DETROIT CONNECT PLATFORM HARDWARE		
8D1-315	5 YEARS DAIMLER CONNECTIVITY BASE PACKAGE (FEATURES VARY BY MODEL) POWERED BY DETROIT CONNECT ON CUMMINS ENGINES		
8D4-998	NO FUEL SYSTEMS DATA SERVICE(SCO)		
162-002	IGNITION SWITCH CONTROLLED ENGINE STOP		
329-133	FOUR EXTRA HARDWIRED SWITCHES IN DASH, ROUTE TO BETWEEN SEATS, BLUNTCUT		
4C1-025	HARDWIRE SWITCH #1, ON/OFF LATCHING, 20 AMPS IGNITION POWER		
4C2-026	HARDWIRE SWITCH #2, ON/OFF LATCHING, 10 AMPS BATTERY POWER		
4C3-017	HARDWIRE SWITCH #3, ON/OFF LATCHING, 10 AMPS BATTERY POWER		
4C4-016	HARDWIRE SWITCH #4, ON/OFF LATCHING, 20 AMPS IGNITION POWER		
81Y-005	PRE-TRIP INSPECTION FEATURE FOR EXTERIOR LAMPS ONLY		

Application Version 12.0.703  
 Data Version PRL-30X.018  
 WSTR 47X ODOT 023A-26  
 BEACHWOOD

12/31/2025 9:35 AM

Page 13 of 18

Prepared for:  
 BEACHWOOD CITY OF  
 23355 Mercantile Rd  
 Beachwood, OH 44122  
 Phone: 2162921495

Prepared by:  
 Greg Simonic  
 CLEVELAND FREIGHTLINER, INC.  
 10901 Brookpark Rd  
 Parma, OH 44130  
 Phone: 216-267-4800

Data Code	Description	Weight Front	Weight Rear
482-001	STANDARD TRACTOR PROTECTION VALVE		
883-001	TRAILER HAND CONTROL BRAKE VALVE	2	
842-006	DIGITAL TURBO AIR PRESSURE IN DRIVER DISPLAY		
836-015	DIGITAL VOLTAGE DISPLAY INTEGRAL WITH DRIVER DISPLAY		
304-030	ROTARY HEADLAMP SWITCH, MARKER LIGHTS/HEADLIGHTS SWITCH WITH PULL OUT FOR OPTIONAL FOG/ROAD LAMPS		
882-021	TWO VALVE PARKING BRAKE SYSTEM WITH DASH VALVE CONTROL AUTONEUTRAL AND WARNING INDICATOR		
299-020	SELF CANCELING TURN SIGNAL SWITCH WITH DIMMER, HEADLAMP FLASH, WASH/WIPE/INTERMITTENT		
48H-002	QUICKFIT POWERTRAIN INTERFACE CONNECTOR LOCATED BETWEEN SEATS WITH BLUNTCUTS		

#### Design

065-000 PAINT: ONE SOLID COLOR

#### Color

980-5F6 CAB COLOR A: L0006EY WHITE ELITE EY  
 986-020 BLACK, HIGH SOLIDS POLYURETHANE CHASSIS PAINT

#### Extended Front Axle Coverage

WA4-035 AXLE: DETROIT FRONT ONLY: HD MODERATE 5 YEARS/100,000 MILES/161,000 KM EXTENDED AXLE COVERAGE

#### Certification / Compliance

996-001 U.S. FMVSS CERTIFICATION, EXCEPT SALES CABS AND GLIDER KITS

### TOTAL VEHICLE SUMMARY

#### Weight Summary

	Weight Front	Weight Rear	Total Weight
Factory Weight <sup>+</sup>	7830 lbs	7052 lbs	14882 lbs
Total Weight <sup>+</sup>	7830 lbs	7052 lbs	14882 lbs

#### Extended Warranty

Application Version 12.0.703  
 Data Version PRL-30X.018  
 WSTR 47X ODOT 023A-26  
 BEACHWOOD

12/31/2025 9:35 AM

Page 14 of 18

**Prepared for:**  
BEACHWOOD CITY OF  
23355 Mercantile Rd  
Beachwood, OH 44122  
Phone: 2162921495

**Prepared by:**  
Greg Simonic  
CLEVELAND FREIGHTLINER, INC.  
10901 Brookpark Rd  
Parma, OH 44130  
Phone: 216-267-4800

WAI-47H CUM 2017 L9: HD1 MD DTY 5 YEARS / 100,000 MILES / 161,000 KM  
EXTENDED WARRANTY. FEX APPLIES

WAX-101 CUM 2017 L9: AT3 MD DTY 5 YEARS / 100,000 MILES / 161,000 KM  
AFTERTREATMENT. FEX APPLIES

WBB-27T EXT ULTIMATE TRUCK CHASSIS: US HD STANDARD-MODERATE 5  
YEARS/100,000 MILES/161,000 KM.

WAL-217 AXLE: NON-DETROIT SINGLE REAR ONLY: HD MODERATE 5  
YEARS/100,000 MILES/161,000 KM EXTENDED COVERAGE

(+) Weights shown are estimates only.

If weight is critical, contact Customer Application Engineering.

(\*\*\*) All cost increases for major components (Engines, Transmissions, Axles, Front and Rear Tires) and government mandated requirements, tariffs, and raw material surcharges will be passed through and added to factory invoices.

Prepared for:  
 BEACHWOOD CITY OF  
 23355 Mercantile Rd  
 Beachwood, OH 44122  
 Phone: 2162921495

Prepared by:  
 Greg Simonic  
 CLEVELAND FREIGHTLINER, INC.  
 10901 Brookpark Rd  
 Parma, OH 44130  
 Phone: 216-267-4800

## D I M E N S I O N S

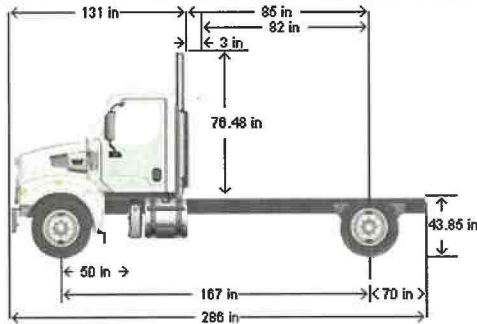

### VEHICLE SPECIFICATIONS SUMMARY - DIMENSIONS

Model .....	47X
Wheelbase (545) .....	4240MM (167 INCH) WHEELBASE, SFA ONLY
Rear Frame Overhang (552) .....	1775MM (70 INCH) REAR FRAME OVERHANG
Fifth Wheel (578) .....	NO FIFTH WHEEL
Mounting Location (577) .....	NO FIFTH WHEEL LOCATION
Maximum Forward Position (in) .....	0
Maximum Rearward Position (in) .....	0
Amount of Slide Travel (in) .....	0
Slide Increment (in) .....	0
Desired Slide Position (in) .....	0.0
Cab Size (829) .....	111.6 INCH BBC CONVENTIONAL ALUMINUM CAB
Sleeper (682) .....	NO SLEEPER BOX/SLEEPER/CAB
Exhaust System (016) .....	RH OUTBOARD UNDER STEP MOUNTED HORIZONTAL AFTERTREATMENT SYSTEM ASSEMBLY WITH RH B-PILLAR MOUNTED VERTICAL TAILPIPE
Cab to Body Clearance (in) .....	3.0

### TABLE SUMMARY - DIMENSIONS

Prepared for:  
 BEACHWOOD CITY OF  
 23355 Mercantile Rd  
 Beachwood, OH 44122  
 Phone: 2162921495

Prepared by:  
 Greg Simonic  
 CLEVELAND FREIGHTLINER, INC.  
 10901 Brookpark Rd  
 Parma, OH 44130  
 Phone: 216-267-4800

Dimensions	Inches
Bumper to Back of Cab (BBC)	131.1
Bumper to Centerline of Front Axle (BA)	49.6
Front Axle to Back of Cab (AC)	81.5
Min. Cab to Body Clearance (CB)	3.0
Back of Cab to Centerline of Rear Axle(s) (CA)	85.4
Effective Back of Cab to Centerline of Rear Axle(s) (Effective CA)	82.4
Back of Cab Protrusions (Exhaust/Intake) (CP)	2.0
Back of Cab Protrusions (Side Extenders/Trim Tab) (CP)	0.0
Back of Cab Protrusions (CNG Tank)	0.0
Back of Cab Clearance (CL)	3.0
Back of Cab to End of Frame	155.3
Cab Height (CH)	76.5
Wheelbase (WB)	166.9
Frame Overhang (OH)	69.9
Overall Frame Length	285.4
Overall Length (OAL)	286.4
Rear Axle Spacing	0.0
Unladen Frame Height at Centerline of Rear Axle	43.9

Performance calculations are estimates only. If performance calculations are critical, please contact Customer Application Engineering.

Prepared for:  
 BEACHWOOD CITY OF  
 23355 Mercantile Rd  
 Beachwood, OH 44122  
 Phone: 2162921495

Prepared by:  
 Greg Simonic  
 CLEVELAND FREIGHTLINER, INC.  
 10901 Brookpark Rd  
 Parma, OH 44130  
 Phone: 216-267-4800

## Q U O T A T I O N

### WESTERN STAR 47X

SET FORWARD AXLE - TRUCK  
 CUM L9 360 HP @ 2200 RPM; 2200 GOV RPM, 1150 LB-  
 FT @ 1200 RPM  
 ALLISON 3000 RDS AUTOMATIC TRANSMISSION WITH  
 PTO PROVISION  
 MERITOR RS-26-185 26,000# T-SERIES SINGLE REAR  
 AXLE  
 30,000# FLAT LEAF SPRING REAR SUSPENSION WITH  
 HELPER AND RADIUS ROD

DETROIT DA-F-20.0-5 20,000# FL1 71.0 KPI/3.74 DROP  
 SINGLE FRONT AXLE  
 20,000# FLAT LEAF FRONT SUSPENSION  
 111.6 INCH BBC CONVENTIONAL ALUMINUM CAB  
 4240MM (167 INCH) WHEELBASE, SFA ONLY  
 13.0MM X 87.0MM X 311.0MM STEEL FRAME  
 (0.51X3.43X12.24 INCH) 120 KSI  
 1775MM (70 INCH) REAR FRAME OVERHANG

		PER UNIT		TOTAL
VEHICLE PRICE	TOTAL # OF UNITS (1)	\$	133,697	\$ 133,697
EXTENDED WARRANTY		\$	5,995	\$ 5,995
DEALER INSTALLED OPTIONS		\$	0	\$ 0
<b>CUSTOMER PRICE BEFORE TAX</b>		<b>\$</b>	<b>139,692</b>	<b>\$ 139,692</b>

### TAXES AND FEES

TAXES AND FEES		\$	0	\$ 0
OTHER CHARGES		\$	0	\$ 0

### TRADE-IN

TRADE-IN ALLOWANCE		\$	(0)	\$ (0)
--------------------	--	----	-----	--------

<b>BALANCE DUE</b>		<b>(LOCAL CURRENCY) \$</b>	<b>139,692</b>	<b>\$ 139,692</b>
--------------------	--	----------------------------	----------------	-------------------

The proposed vehicle/vehicles may be available with safety and collision mitigation options outlined in the specifications if included. If this is a chassis order, please consult with your bodybuilder to ensure the specification includes all dimensions, ratings, and necessary components for body installation. All specifications and pricing are subject to final production, engineering review, availability, Mfg. surcharges and tariffs. The purchasing entity is responsible for determining eligibility and requesting permission for cooperative purchase programs. Invoicing will occur upon delivery to the customer or dropship point and will be payable upon receipt. Payment is due on receipt of the invoice. Titles will be transferred and delivered promptly upon receipt of payment. Reconfirm pricing after 30 days. A purchase order or signed proposal agrees to the pricing, specifications, and terms, and the cooperative contract rules if applicable unless other arrangements are agreed upon but does not guarantee production. Vehicle/Chassis is proposed under Ohio Department of Transportation State contract number DOT023A26-9 cooperative pricing. Pricing is valid for Ohio municipal purchases and eligibility coincides with contract terms and dates. Contracts information can be found at the link below.

[https://ohiobuys.ohio.gov/page.aspx/en/ctr/contract\\_manage\\_public/32231](https://ohiobuys.ohio.gov/page.aspx/en/ctr/contract_manage_public/32231)

### APPROVAL:

Please indicate your acceptance of this quotation by signing below:

Customer: X \_\_\_\_\_ Date: \_\_\_ / \_\_\_ / \_\_\_.



8200 Tyler Blvd. Suite H, Mentor, OH 44060  
**PHONE: (440) 357-5344 FAX: (440) 357-1942**  
 concordroadequipment.com

**Quote Number**  
**90528**  
 Quote Valid for 90 days

Date: **11/11/2025** Ship To: **BEACHWOOD SERVICE DEPT.**  
 Submitted To: **BEACHWOOD, CITY OF**  
**25325 FAIRMOUNT BLVD.**  
**BEACHWOOD, OHIO 44122** Attention: **MARK DECESS**  
 Attention: **MARK DECESS** Phone: **(216) 292-1495** Phone: **(216) 829-5719**

**Account Mgr. Jeff Warfield**  
**Phone No. (440) 336-0758**  
**Delivery Period**  
 "See Terms and Conditions"

STATE OF OHIO STATE TERM SCHEDULE CONTRACT SCHEDULE NUMBER: 800925; INDEX NUMBER: ST5515

ONE (1) MORE OR LESS CONCORD MINUTEMAN TRUCK EQUIPMENT PACKAGE TO BE INSTALLED ON CUSTOMER SUPPLIED CAB AND CHASSIS TO INCLUDE THE FOLLOWING:

**[BEGIN BASE CONFIGURATION]**

**CONCORD "PATRIOT SDS" SEVERE DUTY STAINLESS SERIES DUMP BODY AND HOIST**

General

- 304-2B stainless steel Construction
- 10 foot inside length
- 84 inch inside width
- 96 inch outside width
- 6.5 – 8.2 struck cubic yard capacity

Dump Body Sides

- 30-inch-tall (inside floor to top of tailgate) 7 gauge 304-2B stainless steel sides
- Fully boxed dirt shedding top rails
- Integral dirt shedding sloped lower rub rails
- Integral full length formed horizontal intermediate bracing
- Front body corner brace
- Full depth rear corner pillar with dirt shedding top cap

Dump Body Tailgate

- 38 inch-tall (inside floor to top of tailgate) 7 gauge 304-2B stainless steel tailgate
- Six (6) panel style bracing
- Fully boxed perimeter with dirt shedding top and bottom rails
- One (1) intermediate dirt shedding horizontal rail
- Two (2) intermediate vertical rails
- Heavy-duty 1-inch-thick stainless steel "off-set flared plate" upper offset hinge hardware
- 1-1/2-inch diameter stainless steel upper tailgate pins with grease zerks
- Heavy-duty 1-inch-thick stainless steel "plate" lower latching fingers
- 1-1/2-inch diameter stainless steel lower tailgate latching pins
- Air operated release mechanism with cylinder located vertically in rear dump body corner post
- Lifting ring, stainless steel-top center of tailgate

Dump Body Bulkhead

- 7 gauge 304-2B stainless steel front bulkhead
- Three (3) bend formed horizontal top rail
- One (1) additional horizontal intermediate bracing

Dump Body Floor & Understructure

- Crossmemberless western style "smooth bottom" understructure
- Single one (1) piece "Tub" design constructed of 1/4-inch thick AR400 abrasion/impact resistant steel
- 3/4-inch stainless steel plate BOXED TRAPEZOIDAL TUBULAR longitudinals

Dump Body Hoist

- Class 60 Under body scissors hoist
- 8-inch bore x 23.625 stroke cylinder
- Double acting power up and power down
- Rated at 20.8-ton dumping capacity
- 50-degree dump angle in this configuration
- Heavy-duty greaseable rear hinge assembly with removable hinge pin
- One (1) safety body prop

Dump Body Cab Shield

- 24-inch 7 gauge 304-2B stainless steel



8200 Tyler Blvd. Suite H, Mentor, OH 44060  
**PHONE: (440) 357-5344 FAX: (440) 357-1942**  
**concordroadequipment.com**

**Quote Number**  
**90528**  
Quote Valid for 90 days

Date: **11/11/2025** Ship To: **BEACHWOOD SERVICE DEPT.**  
Submitted To: **BEACHWOOD, CITY OF** **23355 MERCANTILE ROAD**  
**25325 FAIRMOUNT BLVD.** **BEACHWOOD, OHIO 22659**  
**BEACHWOOD, OHIO 44122** Attention: **MARK DECRESS**  
Attention: **MARK DECRESS** Phone: **(216) 292-1495** Phone: **(216) 829-5719**

**Account Mgr. Jeff Warfield**  
**Phone No. (440) 336-0758**  
**Delivery Period**  
"See Terms and Conditions"

- Load bearing type
- Fully welded to front body bulkhead interior
- Provisions for mounting forward and side facing warning lamps
- Provisions for mounting forward FMVSS108 marker lamps

Body Passivation

- All dump body stainless steel welds to receive "chemical passivation" to remove free iron surface contamination and to promote the formation of chromium-nickel oxide protective barrier
- Dump body exterior left in natural 2B stainless steel finish

**CHASSIS AND DUMP BODY RELATED COMPONENTS**

Rear Chassis Pintle Tow

- Rear chassis frame-mounted 1-inch-thick pintle plate
- Dove tail full depth style enclosing rear frame rails and dropping below to provide correct mounting height of pintle
- 55 degree offset lashing safety D-rings
- 30-ton swivel type pintle hook

Rear Fenders

- Poly fenders over rear chassis tires
- Fenders to be "BLUE" in color
- Fenders mounted using heavy duty stainless steel "offset" mounting hardware

Mud Flaps & Brackets

- Rear stainless steel ½ shields behind rear tires
- Rear mud flaps with stainless steel mounting hardware behind rear tires

Dump Body Mounted Inspection Steps

- Two (2) dump body mounted steps, stainless steel grip strut style
- Steps mounted to dump body side, one above the other
- Grab assist handles, stainless steel, one (1) each fore/aft of body mounted steps

Mounted Inspection Ladder

- One three (3) step fold-up stow-away
- Installed street side below dump body mounted steps
- All stainless-steel construction
- Grip strut style rungs

Folding Footstep

- One (1) folding footstep, Buyers Products #5236586 with integral grab handle and zinc plated finish
- Step includes stainless steel spring that keeps step in the folded "Closed" or "Open" position
- Step to be installed drivers' side front bulkhead corner of dump body
- Height of step location to be approximately equal the height of chassis cab step to allow operator to partially exit chassis cab and view inside of dump body

Dump Body Vibrator

- 12-volt dc
- Mounted underside of dump body from heavy duty steel mounting plate
- Includes safety break-away chain
- Includes hi-amp circuit breaker
- In chassis cab momentary on/off push button activation switch

Hardwood sideboards

- Nominal 2 inches thick by 8 inches tall
- Painted natural clear coat
- Installed on top of body sides in front and rear corner sideboard pockets

Tailgate Lifting Ring

- Stainless steel construction
- Mounted center upper rail of tailgate

Tarping System

- None Included



8200 Tyler Blvd. Suite H, Mentor, OH 44060  
**PHONE: (440) 357-5344 FAX: (440) 357-1942**  
**concordroadequipment.com**

**Quote Number**  
**90528**  
Quote Valid for 90 days

Date: **11/11/2025** Ship To: **BEACHWOOD SERVICE DEPT.**  
Submitted To: **BEACHWOOD, CITY OF**  
**23355 MERCANTILE ROAD**  
**25325 FAIRMOUNT BLVD.**  
**BEACHWOOD, OHIO 44122** Attention: **MARK DECESS**  
Attention: **MARK DECESS** Phone: **(216) 292-1495** Phone: **(216) 829-5719**

**Account Mgr. Jeff Warfield**  
**Phone No. (440) 336-0758**  
**Delivery Period**  
"See Terms and Conditions"

Tarp Tie Down Rails

- None Included

Catwalk Rails

- Constructed of stainless-steel grip strut style material
- Rails installed on stainless steel brackets attached to lower sloping rub rails of dump body

Rear Dump Body Corner Post Lamp Boxes

Whelen 700 series stainless steel lamp boxes recess installed in rear corner post of dump body, one (1) streetside x one (1) curbside

- Boxes constructed of stainless steel
- Each box to allow installation of Whelen 700 series stop/tail/turn, backup, and rear warning lamps

Tool/Shovel Holder

- None Included

Conspicuity Tape System

- Alternating red and white reflective
- Tailgate perimeter bracing

**CENTRAL HYDRAULIC SYSTEM**

Power Take-off and Hydraulic Pump

- Transmission mounted 12 volt actuated hot shift power take off
- 17 gallon per minute gear style positive displacement hydraulic pump
- For ease of maintenance, hydraulic pump mounted to hotshift PTO via sealed and pressure lubricated PTO extension shaft housing
- PTO on/off switch to be clearly identified, located within easy reach and view of operator

Hydraulic Directional Control Valve

- Three (3) section hydraulic directional control valve rated @ nominal working flow of 34 gpm and maximum flow of 55 gpm
- Valve adjustable relief set at 2,000 psi and rated for maximum of 5,440 psi
- Valve dump body hoist power down port set at 500-750 psi max
- All valve work ports SAE O-ring type
- Valve to operate double acting dump body hoist, double acting snowplow lift ram, and double acting snowplow power angling
- Valve to include high pressure power beyond outlet to provide pressurized oil to separate spreader control system manifold valve assembly
- Valve remote mounted in combination hydraulic oil reservoir/valve enclosure

Operators and Hydraulic Directional Valve Controls

- Valve sections shifted via spool mounted air shift solenoids
- Three (3) in cab air controllers to operate double acting dump body hoist, double acting plow lift, and double acting plow power angle functions mounted in a dual axis stand
- Dump body hoist controller locking type to prevent accidental operation
- Color coded airlines with push lock couplers between in cab operators air controllers and valve mounted air shift solenoids
- In chassis cab operator's dual axis stand mounted to chassis floor mounted reinforcement plate
- Air control system includes tractor air protection valve and adjustable finite filter/regulator assembly
- Tractor air protection valve direct mounted in chassis air tank
- For ease of access, finite filter/regulator assembly mounted in combination hydraulic oil reservoir/valve enclosure

Electronic Granular Materials Spreader Controller

- Muncie MESP300 series electronic spreader control package
- System to operate granular materials insert hopper spreader with single auger delivery system and broadcast spinner
- System capable of manual, ground speed trigger, or ground speed orientation modes of control
- System includes in chassis cab mounted operators dual circuit spreader electronic operator's controller and remote mounted manifold valve
- In cab operator's controller includes soft touch light paddle switches that are lit green when system is in auto mode and red when system is in manual mode
- In cab operator's controller also includes system "pause" and system "blast" features

Hydraulic Oil Reservoir/Combo Valve Enclosure

- Stainless steel chassis frame mounted combination hydraulic oil reservoir/valve enclosure
- Thirty (35) gallon capacity
- Cylindrical design for shedding of debris



8200 Tyler Blvd. Suite H, Mentor, OH 44060  
**PHONE: (440) 357-5344 FAX: (440) 357-1942**  
**concordroadequipment.com**

**Quote Number**  
**90528**  
Quote Valid for 90 days

Date: **11/11/2025** Ship To: **BEACHWOOD SERVICE DEPT.**  
Submitted To: **BEACHWOOD, CITY OF** **23355 MERCANTILE ROAD**  
**25325 FAIRMOUNT BLVD.** **BEACHWOOD, OHIO 22659**  
Attention: **MARK DECRESS** Phone: **(216) 292-1495** Attention: **MARK DECRESS** Phone: **(216) 829-5719**

**Account Mgr. Jeff Warfield**  
**Phone No. (440) 336-0758**  
**Delivery Period**  
"See Terms and Conditions"

- Hinged cover for ease of access to hydraulic system valving
- 8-inch diameter rear cleanout reservoir access cover
- Filler breather cap
- Sight level/temperature gauge
- Magnetic drain plug
- 100-micron suction port strainer
- Suction port system service ball valve
- Powder coated steel reservoir mounting brackets
- 10-micron spin on replaceable oil filter with condition indicator
- Analog hydraulic pressure gauge (hydraulic valve port mounted)

#### Automatic Low Hydraulic Oil Shut Down System

- Interrupts hot shift PTO operation in the event of low hydraulic oil
- Hydraulic reservoir mounted oil level sensor
- In-cab indicator lamp and warning buzzer
- Momentary system operators override switch to allow emergency stowing of deployed equipment when necessary
- Low oil override switch to be clearly identified, located within easy reach and view of operator

#### Hydraulic Plumbing and Miscellaneous Related

- Four (4) high pressure stainless steel rigid intermediate tubes to rear of chassis for spreader auger/spinner hydraulic pressure and return flows
- Four (4) high pressure stainless steel rigid intermediate tubes to front of chassis for snowplow lift cylinder and power angling circuits
- Short high pressure flexible hydraulic hoses between work ports and both ends of each high-pressure stainless steel rigid tubes
- Stainless steel industrial poppet type quick couplers, four (4) at the rear of chassis for spreader connections and two (2) at front of chassis for snowplow power angling connections
- All hydraulic plumbing rigid tubing and hydraulic hoses assemblies guarded or shielded where sharp edges or intense heat is present
- All hydraulic plumbing rigid tubing and hydraulic hoses assemblies clamped, bracketed, and or tied every 24 inches
- All hydraulic system returns flow circuits to enter a stainless-steel return line manifold assembly and exit manifold one (1) common return line direct to inlet of hydraulic oil return filter head
- Hydraulic oil reservoir filled with AW32 non foaming low temperature hydraulic oil
- Hydraulic system will be fully adjusted, tested, and operational upon delivery

## **BASE ELECTRICAL SYSTEM**

#### In Cab Power Distribution

- All components mounted to aluminum distribution panel
- As required, the power distribution panel to include all necessary relays, circuit breakers, terminal strips, etc.
- Power distribution panel includes a clear poly cover and color-coded circuit diagram affixed for quick referencing of all body related electrical circuitry

#### Dump Body Lighting-FMVSS108

- All LED type lamps
- Two (2) recessed Red LED marker lamps in lower rear apron/bolster of dump body
- Two (2) recessed Red LED marker lamps side facing in lower rear corner post of dump body
- Two (2) recessed Red LED clearance lamps rear facing in upper rear corner post of dump body
- Three (3) recessed Red LED center identification lamps center rear of dump body
- Two (2) recessed Amber clearance LED forward facing cabshield assembly
- Rear license plate light

#### Warning Light System-Whelen

- Whelen SYS704-D
- One (1) Whelen 700 series recessed AMBER warning lamp, curb side dump body rear corner post stainless steel lamp box
- One (1) Whelen 700 series recessed GREEN warning lamp, curb side dump body rear corner post stainless steel lamp box
- One (1) Whelen L31HAF 360- degree AMBER, below and center of body cabshield
- Two (2) Whelen 700 series recessed Red LED stop, tail and turn lamps, one (1) each street and curb side dump body rear corner post stainless steel lamp boxes
- Two (2) Whelen 700 series recessed LED Back up lamps, one (1) each street and curb side dump body rear corner post stainless steel lamp boxes



8200 Tyler Blvd. Suite H, Mentor, OH 44060  
**PHONE: (440) 357-5344 FAX: (440) 357-1942**  
**concordroadequipment.com**

**Quote Number**  
**90528**  
Quote Valid for 90 days

Date: **11/11/2025** Ship To: **BEACHWOOD SERVICE DEPT.**  
Submitted To: **BEACHWOOD, CITY OF**  
**23355 MERCANTILE ROAD**  
**25325 FAIRMOUNT BLVD.**  
**BEACHWOOD, OHIO 44122** Attention: **MARK DECESS**  
Attention: **MARK DECESS** Phone: **(216) 292-1495** Phone: **(216) 829-5719**

**Account Mgr. Jeff Warfield**  
**Phone No. (440) 336-0758**  
**Delivery Period**  
"See Terms and Conditions"

Snowplow Lamps

- Buyers Products #1312200
- "Heated" LED high intensity snowplow lights
- Die cast aluminum housing with tempered glass lens
- Hi beam/Low Beam
- Integral marker and turn signals
- Chassis hood mounted
- Mounted on stainless steel light brackets
- Six (6) pin Deutsch connector

Spinner/Work Lamps

- Two (2)- One (1) each mounted street and curb side rear of dump body
- Heated LED type
- On/off switch to be clearly identified, located within easy reach and view of operator

Rear Vision Camera System

- *None Included*

Air and Pavement Temperature Sensor

- *None Included*

Trailer Brake Controller

- Tekonsha 80500 POD series or equal
- Solid state electronic timed controller type
- One and two axle trailers

Dump Body Up Warning

- Remote hoist subframe mounted sealed switch trigger operated
- In chassis cab warning light with alarm

Heated Wiper Blades

- *None Included*

Base Electrical Components Installation Guidelines

- All required wiring/wiring harnesses covered in abrasive resistant split loom
- All wiring harnesses to be properly secured and shielded from sharp edges and heat
- All required electrical hardware, switches, and sealed connectors
- System fully tested, and operational

**CHASSIS MOUNTED SNOWPLOW HITCH & RELATED**

Concord Manufactured Titan Series TTN-400CL

- Heavy duty low profile
- CENTER lift cap/ lift cylinder configuration
- Telescopic adjustable lift arm that folds down for storage

Lift Ram

- 4 x 6-inch double acting lift ram
- Nitrated cylinder rod for corrosion protection

H-Frame Mounting

- Chassis specific mounting hitch mounting group
- One (1) piece 5/8-inch-thick steel reinforced side push plates
- Sides plates offset formed for chassis wide frame configuration
- Formed offset side plates include "pass through" gusseting for additional strength
- All grade 8 fasteners with "Stover" type locking nuts

Quick Connect/Disconnect Coupler

- Drop pin QAC style quick attach/detach coupler
- Coupler "pinned on" and removable to allow installation of 2 pin style plow attachment

Heavy Duty Bumper

- Heavy duty formed channel plow hitch mounted bumper



8200 Tyler Blvd. Suite H, Mentor, OH 44060  
**PHONE: (440) 357-5344 FAX: (440) 357-1942**  
**concordroadequipment.com**

**Quote Number**  
**90528**  
 Quote Valid for 90 days

Date: **11/11/2025** Ship To: **BEACHWOOD SERVICE DEPT.**  
 Submitted To: **BEACHWOOD, CITY OF** **23355 MERCANTILE ROAD**  
**25325 FAIRMOUNT BLVD.** **BEACHWOOD, OHIO 22659**  
 Attention: **MARK DECRESS** Phone: **(216) 292-1495** Attention: **MARK DECRESS**  
 Phone: **(216) 829-5719**

**Account Mgr. Jeff Warfield**  
**Phone No. (440) 336-0758**  
**Delivery Period**  
 "See Terms and Conditions"

- Two- piece design
- Constructed of ¼ inch steel plate

**Paint**

- Entire hitch assembly sandblasted to remove mill scale
- Phosphate rinsed
- Powder coated gloss black

**GRANULAR MATERIALS SPREADER**

Buyers 14510F573121 Heavy Duty Municipal Hopper Spreader

- 10-foot-long x 82-inch-wide x 57-inch-tall hopper
- Entire hopper and Spinner chute constructed of 10 gauge 304-2B stainless steel construction
- 7.0 struck cubic yard capacity

Auger Delivery System

- Single 7 inch auger flighting
- Auger flighting progressive pitched for even unloading from front of hopper to rear discharge spinner chute
- All auger flighting hard-faced for extended wear/durability
- Hydraulic drive motor direct coupled to auger

Spinner Assembly

- Swing up spinner chute for ease of off-loading and storage
- Spinner assembly includes manual assist winch
- Adjustable height spinner chute extension

Hopper Top Screens and Miscellaneous

- Powder coated four section hinged top screens
- Inverted vee over auger
- Corded rubber side skirts/drapes
- Front ratchet strap tie down kit
- Rear stainless steel latch bar
- GALVANIZED STEEL self-loading /unloading spreader storage stand
- Hydraulic hookup hoses and stainless-steel quick couplers

**POWER ANGLING SNOWPLOW**

Buyers Super J 42120-CSTE heavy duty snowplow, #1662510301

- 10-foot-long x 42-inch-tall 7 gauge steel moldboard
- Torsion spring safety trip edge
- Full moldboard width structural tubing push frame
- Three position adjustable moldboard pitch/attach angle
- Hydraulic ram reversing with short A-frame
- 4-inch nitrated steel reversing hydraulic rams
- Two chain lift system
- Drop pin style loop coupler on oscillating drive bar
- Storage parking stand
- Hydraulic hoses with stainless steel quick couplers
- Plow end markers

**MISCELLANEOUS**

- Body Passivation
- All dump body stainless steel welds to receive "chemical passivation" to remove free iron surface contamination and to promote the formation of chromium-nickel oxide protective barrier



8200 Tyler Blvd. Suite H, Mentor, OH 44060  
**PHONE: (440) 357-5344 FAX: (440) 357-1942**  
 concordroadequipment.com

Total  
284,314.46

**Quote Number**  
90528  
Quote Valid for 90 days

Date: 11/11/2025  
 Submitted To: BEACHWOOD, CITY OF  
 25325 FAIRMOUNT BLVD.  
 BEACHWOOD, OHIO 44122  
 Attention: MARK DEGRESS

Phone: (216) 292-1495

Ship To: BEACHWOOD SERVICE DEPT.  
 23355 MERCANTILE ROAD  
 BEACHWOOD, OHIO 22659  
 Attention: MARK DEGRESS  
 Phone: (216) 829-5719

Account Mgr. Jeff Warfield  
 Phone No. (440) 336-0758  
**Delivery Period**  
 "See Terms and Conditions"

YOUR BASE CONFIGURATION NET SALES PRICE PER UNIT \$ 144,622.46

Authorized by \_\_\_\_\_  
 JEFFERY S. WARFIELD - PRESIDENT

I /We hereby accept the above quotation including all terms and conditions, and place an order for the proposed item(s) for a total amount of \$ \_\_\_\_\_ (when applicable, please include any proposed/selected options in the total amount)

Accepted By \_\_\_\_\_ Date Signed \_\_\_\_\_

Purchase Order Number \_\_\_\_\_

bed 144,622.46  
 truck 139,692  
 -----  
 284,314.46



8200 Tyler Blvd. Suite H, Mentor, OH 44060  
**PHONE: (440) 357-5344 FAX: (440) 357-1942**  
 concordroadequipment.com

**Quote Number**  
**90528**  
 Quote Valid for 90 days

Date: **11/11/2025**  
 Submitted To: **BEACHWOOD, CITY OF**  
**25325 FAIRMOUNT BLVD.**  
**BEACHWOOD, OHIO 44122**

Ship To: **BEACHWOOD SERVICE DEPT.**  
**23355 MERCANTILE ROAD**  
**BEACHWOOD, OHIO 22659**  
 Attention: **MARK DECRESS**  
 Phone: **(216) 829-5719**

Attention: **MARK DECRESS** Phone: **(216) 292-1495**

**Account Mgr. Jeff Warfield**  
**Phone No. (440) 336-0758**  
**Delivery Period**  
 "See Terms and Conditions"

- Dump body exterior left in natural 304-2B stain stainless steel finish
- Spreader hopper and spinner left in natural 304-2B
- Prep and Painting
- Dump body understructure, front and rear chassis mounted hitches, and miscellaneous non-stainless steel powdered coated when applicable or painted with two-part epoxy primer and painted with gloss black paint

[END BASE CONFIGURATION]

**TERMS AND CONDITIONS**

**MINIMUM CHASSIS REQUIREMENTS**

Chassis to have a USABLE CAB to AXLE (CA) dimension of approximately [84.00-88.00] inches; have a provision for TRANSMISSION MOUNTED POWER TAKEOFF; Clear frame behind chassis cab street and curb sides to front of chassis suspension; Integral OEM front frame extension of 12 inches minimum; OEM In chassis cab body up fitter circuits and switches including, when applicable, snowplow light circuit, provision for electric trailer brakes, provisions for chassis ground speed interface, and for chassis transmission mounted "Hotshift PTO". Chassis specifications should be provided prior to placing an order to ensure compatibility.

Concord Road Equipment Mfg., LLC not responsible for incompatibility between proposed components and/or equipment and chassis components and/or equipment. Discrepancies in the requested minimum chassis requirements may result in additional cost, resulting in a change order request and approval, prior to installation of proposed components and equipment.

**PAYMENT DISCOUNTS**

Per our Ohio Department of Administrative Services Contract Schedule #800925, Index #STS515 an additional 0.5% (one-half of one percent) discount is available for payment(s) of invoice(s) within twenty (20) days of receipt. Payment discount will be noted on the invoice(s).

**WARRANTY INFORMATION- CONCORD ROAD EQUIPMENT MFG., LLC DUMP BODY/SNOW AND ICE CONTROL EQUIPMENT PACKAGE**

Concord Road Equipment Mfg., LLC. truck equipment packages include a warranty for a total period of FOUR (4) YEARS AS FOLLOWS; Months 1 through 12 at 100% on electrical components, hydraulic components, structural and fabricated components-parts and labor; Months 13 through 24 at 50% on structural and fabricated components- parts and labor; Months 25 through 48 at 25% structural and fabricated components labor only. When applicable, other suppliers/component warranties that exceed Concord's base warranty will remain in effect. All warranty periods begin after completion/delivery of equipment, components, and accessories. When applicable, Concord "Titan" series snowplow hitches carry a full 100% parts warranty on structural components only for 60 months. When applicable, TBEI series dump body hoists have a manufacturer parts warranty of 36 months. When applicable, Swaploader hooklift hoist include a manufacturer parts warranty for 36 months. Warranties do not include normally considered wear and maintenance items (such as plow blades, augers, conveyor chains, hydraulic couplers, filters, spinner drive hydraulic motors, spinner disks, chains, sprockets, bearings, etc.); routine adjustments and/or calibrations; abuse, neglect, misuse, and/or improper operation; lack of maintenance (including component corrosion), inspections, and/or training; and/or consequential damages as a result thereof. Under the warranty period, Concord Road Equipment Mfg., LLC reserves the right to replace, repair, rebuild, or substitute with like equipment and/or components at its sole discretion.

**WARRANTIES- AS PROVIDED BY OEM CAB & CHASSIS DEALERS (When Applicable)**

WHEN APPLICABLE, Standard chassis warranties included and provided by OEM chassis dealer. Additional extended warranties are available through the OEM chassis dealer and can be provided at additional cost. Contact OEM chassis dealer for details.

**ESTIMATED DELIVERY PERIOD**

Based on the date of this proposal, the job completion and corresponding delivery period is estimated to be 90-180 DAYS after receipt of the required purchase order(s), letter(s) of intent, letter(s) to proceed, and if applicable, the arrival of chassis(s) to Concord Road Equipment Mfg., LLC. This projected job completion and corresponding delivery period is only an estimate and may be shorter or longer in accordance with the date that your order is placed, the arrival date of required authorizations, delivery date of your chassis(s) to Concord, and lead times of Concord Road Equipment Mfg., LLC primary suppliers at the time your order is placed. Concord Road Equipment Mfg., LLC is not responsible for delays that are beyond its reasonable effort and capability to control including but not limited to; Primary supplier delays and/or product shortages; Delays in freight; Force majeure including but not limited to 1-acts of God, such as severe acts of nature or weather events including floods, fires, earthquakes, tornadoes/hurricanes, or explosions; 2- war, acts of terrorism, and epidemics; 3- acts of governmental authorities such as expropriation, condemnation, and changes in laws and regulations; 4- strikes and labor disputes; 5- and certain accidents. Per Concord Road Equipment Mfg., LLC. Contract 800925 Schedule STS 515 with the Ohio Department of Administrative Services, completed deliveries can range from 60-300 days after receipt of a customer order(s), and when applicable, after the arrival of your chassis(s) to Concord Road Equipment Mfg., LLC.

**INSURANCE**

Your chassis and/or equipment are insured while in Concord Road Equipment's Mfg., LLC possession. This includes all properties, buildings, lots, etc. A copy of our complete "LIMITED LIABILITY" garage-keepers insurance policy is available upon request

A RESOLUTION AUTHORIZING THE MAYOR TO ENTER INTO AN AGREEMENT WITH CLEVELAND FREIGHTLINER, INC. FOR THE PURCHASE OF ONE (1) FREIGHTLINER M2 106 PLUS CAB AND CHASSIS; WAIVING COMPETITIVE BIDDING AND TO ENTER INTO AN AGREEMENT WITH ZORESCO EQUIPMENT FOR THE PURCHASE OF ONE (1) CONSTRUCTION UTILITY BODY; AND DECLARING THIS TO BE AN URGENT MEASURE

WHEREAS, Council by Ordinance No. 1986-79 authorized the Mayor in lieu of competitive bidding by the City to enter into purchase orders with suppliers of products and/or services from a list prepared by the State of Ohio, after the State received competitively bid contracts with such suppliers in accordance with the State laws;

WHEREAS, the Public Works Director has recommended the purchase of one (1) Freightliner M2 106 Cabs and Chassis from Valley Freightliner, Inc. and has recommended the purchase of one (1) Construction Utility Body from Zoresco Equipment for that vehicle, as set forth in the two quotations supplied to this Council;

WHEREAS, the Valley Freightliner, Inc. price quotation to the City of \$116,740 is in accordance with ODOT Contract #1182-5

WHEREAS, the Zoresco Equipment price quotation to the City in in the amount not to exceed \$40,228; and

WHEREAS, the purchase and installation amount for both the one (1) Truck Cab and Chassis and the one (1) Construction Utility Body are for a total amount not to exceed One Hundred Fifty-Six Thousand Nine Hundred Sixty-Eight Dollars and No/Cents (\$156,968.00).

NOW, THEREFORE, BE IT RESOLVED, by the Council of the City of Beachwood, County of Cuyahoga, and State of Ohio that:

Section 1: Based upon the quotation received from Valley Freightliner, Inc., and from Zoresco Equipment, the Mayor is authorized to purchase (1) Freightliner M2 106 Cabs and Chassis from Valley Freightliner, Inc. and to purchase one (1) Construction Utility Body from Zoresco Equipment in a total amount not to exceed One Hundred Fifty-Six Thousand Nine Hundred Sixty-Eight Dollars and No/Cents (\$156,968.00).

Section 2: It is found and determined that all formal actions and deliberations of Council and its committees relating to the passage of this legislation that resulted in formal action were in meetings open to the public where required by Chapter 105 of the Codified Ordinances of the City.

Section 3: This Resolution is declared to be an urgent measure necessary for the public peace, health, safety, or the efficient operation of the City; and for the further reason that it is necessary to have said equipment available for use at the earliest time to serve the public safety and welfare; wherefore, this Resolution shall be in full force and effect immediately upon its passage and approval by the Mayor.

Attest:

I hereby certify this legislation was duly adopted on the 9<sup>th</sup> day of March, 2026, and presented to the Mayor for approval or rejection in accordance with Article III, Section 8 of the Charter on the 10<sup>th</sup> day of March, 2026.

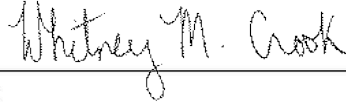

\_\_\_\_\_  
Clerk

Approval:

I have approved this legislation this 10<sup>th</sup> day of March, 2026 and filed it with the Clerk.



\_\_\_\_\_  
Mayor

**BEACHWOOD PUBLIC WORKS DEPARTMENT  
INTER-OFFICE MEMORANDUM**

**TO:** Mayor Justin Berns

**FROM:** Chris Arrietta, Public Works Director

**DATE:** February 23, 2026

**RE:** Council Agenda Item: Equipment Purchase – Construction Utility Truck

---

Public Works is seeking approval to purchase one (1) Freightliner M2 106 Plus Cab and Chassis from Cleveland Freightliner and one (1) Construction Utility Body from Zoresco Equipment for a total cost of \$156,968.00.

This vehicle will replace Unit #90 (2001 IHC 4700 4x2), which is primarily utilized for road construction and sidewalk replacement projects.

The Cab and Chassis will be procured through the Ohio Department of Transportation State Contract (#DOT1182-5). The Utility Body from Zoresco Equipment is a custom-built unit designed to meet the specific needs of our construction crews and is not available through the State Contract.

Please let me know if you require any additional information regarding this request. Upon approval, I would like to place this item on the agenda for the next Council meeting.

Prepared for:  
BEACHWOOD CITY OF  
23355 Mercantile Rd  
Beachwood, OH 44122  
Phone: 2162921495

Prepared by:  
Greg Simonic  
CLEVELAND FREIGHTLINER, INC.  
10901 Brookpark Rd  
Parma, OH 44130  
Phone: 216-267-4800

A proposal for  
**BEACHWOOD CITY OF**

Prepared by  
**CLEVELAND FREIGHTLINER, INC.**  
Greg Simonic

Dec 31, 2025

### Freightliner M2 106 Plus

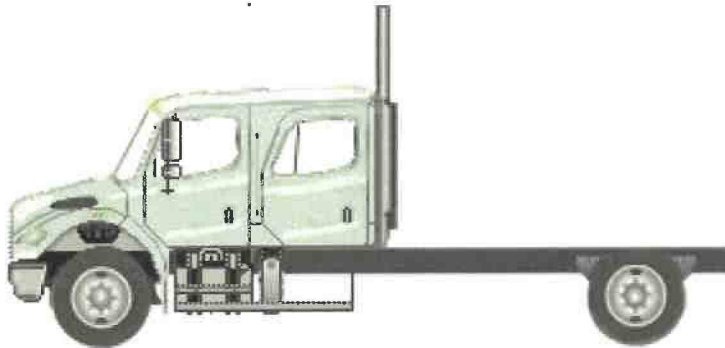

Components shown may not reflect all spec'd options and are not to scale

Truck 116,740  
bed 46,228  

---

156,968

Application Version 12.0.703  
Data Version PRL-30M.018  
FTL 106 118-25 CRWCB  
BEACHWOOD



12/31/2025 9:02 AM

Page 1 of 20

Prepared for:  
 BEACHWOOD CITY OF  
 23355 Mercantile Rd  
 Beachwood, OH 44122  
 Phone: 2162921495

Prepared by:  
 Greg Simonic  
 CLEVELAND FREIGHTLINER, INC.  
 10901 Brookpark Rd  
 Parma, OH 44130  
 Phone: 216-267-4800

## S P E C I F I C A T I O N P R O P O S A L

Data Code	Description	Weight Front	Weight Rear
<b>Price Level</b>			
PRL-30M	M2 PRL-30M (EFF:MY27 ORDERS)		
<b>Data Version</b>			
DRL-018	SPECPRO21 DATA RELEASE VER 018		
<b>Vehicle Configuration</b>			
001-172	M2 106 PLUS CONVENTIONAL CHASSIS	5,709	3,450
004-227	2027 MODEL YEAR SPECIFIED		
002-004	SET BACK AXLE - TRUCK		
019-006	TRAILER TOWING PROVISION AT END OF FRAME WITH SAE J560	10	10
003-001	LH PRIMARY STEERING LOCATION		
<b>General Service</b>			
AA1-003	TRUCK/TRAILER CONFIGURATION		
AA6-002	DOMICILED, USA 50 STATES (EPA CLEAN IDLE LABEL OR NO CLEAN IDLE REQUIRED)		
99D-027	EPA CLEAN IDLE LABEL - (INCLUDES 6X4 INCH LABEL ON LOWER FORWARD OF DRIVER DOOR)		
A85-010	UTILITY/REPAIR/MAINTENANCE SERVICE		
A84-1GM	GOVERNMENT BUSINESS SEGMENT		
AA4-011	FIXED LOAD COMMODITY		
AA5-002	TERRAIN/DUTY: 100% (ALL) OF THE TIME, IN TRANSIT, IS SPENT ON PAVED ROADS		
AB1-008	MAXIMUM 8% EXPECTED GRADE		
AB5-001	SMOOTH CONCRETE OR ASPHALT PAVEMENT - MOST SEVERE IN-TRANSIT (BETWEEN SITES) ROAD SURFACE		
995-091	MEDIUM TRUCK WARRANTY		
A66-99D	EXPECTED FRONT AXLE(S) LOAD : 10000.0 lbs		
A68-99D	EXPECTED REAR DRIVE AXLE(S) LOAD : 20000.0 lbs		
A63-99D	EXPECTED GROSS VEHICLE WEIGHT CAPACITY : 30000.0 lbs		
A70-99D	EXPECTED GROSS COMBINATION WEIGHT : 35000.0 lbs		
<b>Truck Service</b>			

Application Version 12.0.703  
 Data Version PRL-30M.018  
 FTL 106 118-25 CRWCB  
 BEACHWOOD



12/31/2025 9:02 AM

Page 2 of 20

Prepared for:  
 BEACHWOOD CITY OF  
 23355 Mercantile Rd  
 Beachwood, OH 44122  
 Phone: 2162921495

Prepared by:  
 Greg Simonic  
 CLEVELAND FREIGHTLINER, INC.  
 10901 Brookpark Rd  
 Parma, OH 44130  
 Phone: 216-267-4800

Data Code	Description	Weight Front	Weight Rear
AA3-006	UTILITY BODY		
* AF3-999	CUSTOM MFR'S/BODY TYPE IDENTIFICATION		
	FALLSWAY		
AF7-99D	EXPECTED BODY/PAYLOAD CG HEIGHT ABOVE FRAME "XX" INCHES : 32.0 in		

### Tractor Service

AA2-005	FLATBED TRAILER
AH6-001	SINGLE (1) TRAILER

### Engine

101-21Y	CUM B6.7 325 HP @ 2400 RPM, 2600 GOV, 750 LB-FT @ 1800 RPM
---------	--

### Electronic Parameters

79A-068	68 MPH ROAD SPEED LIMIT
79B-000	CRUISE CONTROL SPEED LIMIT SAME AS ROAD SPEED LIMIT
79K-007	PTO MODE ENGINE RPM LIMIT - 1100 RPM
79M-002	PTO ENGINE SPEED CONTROL DEACTIVATED BY SERVICE BRAKE LIGHTLY APPLIED OR PARK BRAKE RELEASED (STATIONARY APPLICATIONS)
79P-004	PTO RPM WITH CRUISE SET SWITCH - 900 RPM
79U-002	PTO GOVERNOR RAMP RATE - 50 RPM PER SECOND
79V-001	FUEL DOSING OF AFTERTREATMENT ENABLED IN PTO MODE-CLEANS HYDROCARBONS AT HIGH TEMPERATURES ONLY
79W-024	CRUISE CONTROL BUTTON PTO CONTROL
79X-007	PTO SPEED 1 SETTING - 1000 RPM
80G-015	PTO MINIMUM RPM - 800
80J-001	REGEN INHIBIT SPEED THRESHOLD - 0 MPH
80S-001	PTO 1, DASH SWITCH, STATIONARY OPERATION

### Engine Equipment

99C-024	EPA 2010/GHG 2024 CONFIGURATION	
13E-001	STANDARD OIL PAN	
105-001	ENGINE MOUNTED OIL CHECK AND FILL	
014-099	SIDE OF HOOD AIR INTAKE WITH FIREWALL MOUNTED DONALDSON AIR CLEANER	
124-1E1	DR 12V 200 AMP 28-SI QUADRAMOUNT PAD ALTERNATOR WITH REMOTE BATTERY VOLT SENSE	
292-235	(2) DTNA GENUINE, FLOODED STARTING, MIN 2000CCA, 370RC, THREADED STUD BATTERIES	10
290-017	BATTERY BOX FRAME MOUNTED	

Application Version 12.0.703  
 Data Version PRL-30M.018  
 FTL 106 118-25 CRWCB  
 BEACHWOOD



12/31/2025 9:02 AM

Page 3 of 20

Prepared for:  
 BEACHWOOD CITY OF  
 23355 Mercantile Rd  
 Beachwood, OH 44122  
 Phone: 2162921495

Prepared by:  
 Greg Simonic  
 CLEVELAND FREIGHTLINER, INC.  
 10901 Brookpark Rd  
 Parma, OH 44130  
 Phone: 216-267-4800

Data Code	Description	Weight Front	Weight Rear
281-001	STANDARD BATTERY JUMPERS		
282-001	SINGLE BATTERY BOX FRAME MOUNTED LH SIDE UNDER CAB		
291-017	WIRE GROUND RETURN FOR BATTERY CABLES WITH ADDITIONAL FRAME GROUND RETURN		
289-001	NON-POLISHED BATTERY BOX COVER		
293-058	NON-ESSENTIAL POSITIVE LOAD DISCONNECT, IN CAB CONTROL SWITCH MOUNTED OUTBOARD OF DRIVER SEAT	2	
295-029	POSITIVE AND NEGATIVE POSTS FOR JUMPSTART LOCATED ON FRAME NEXT TO STARTER	2	
306-015	PROGRESSIVE LOW VOLTAGE DISCONNECT AT 12.3 VOLTS FOR DESIGNATED CIRCUITS	2	
107-032	CUMMINS TURBOCHARGED 18.7 CFM AIR COMPRESSOR WITH INTERNAL SAFETY VALVE		
108-002	STANDARD MECHANICAL AIR COMPRESSOR GOVERNOR		
131-013	AIR COMPRESSOR DISCHARGE LINE		
152-041	ELECTRONIC ENGINE INTEGRAL SHUTDOWN PROTECTION SYSTEM		
128-076	CUMMINS ENGINE INTEGRAL BRAKE WITH VARIABLE GEOMETRY TURBO ON/OFF	20	
016-1DE	RH OUTBOARD UNDER STEP MOUNTED HORIZONTAL AFTERTREATMENT SYSTEM ASSEMBLY WITH RH C-PILLAR MOUNTED VERTICAL TAILPIPE	30	25
28F-014	ENGINE AFTERTREATMENT DEVICE, AUTOMATIC OVER THE ROAD REGENERATION AND VIRTUAL REGENERATION REQUEST SWITCH IN CLUSTER		
239-020	10 FOOT 00 INCH (120 INCH+0/-5.9 INCH) EXHAUST SYSTEM HEIGHT		
237-1D0	RH CURVED VERTICAL TAILPIPE C-PILLAR MOUNTED ROUTED FROM STEP		
23U-001	6 GALLON DIESEL EXHAUST FLUID TANK		
30N-003	100 PERCENT DIESEL EXHAUST FLUID FILL		
43X-005	LH UNDER CAB DIESEL EXHAUST FLUID TANK LOCATION		
23Y-001	STANDARD DIESEL EXHAUST FLUID PUMP MOUNTING		
43Y-001	STANDARD DIESEL EXHAUST FLUID TANK CAP		
242-001	STAINLESS STEEL AFTERTREATMENT DEVICE/MUFFLER/TAILOPIPE SHIELD		
273-058	AIR POWERED ON/OFF ENGINE FAN CLUTCH		
276-001	AUTOMATIC FAN CONTROL WITHOUT DASH SWITCH, NON ENGINE MOUNTED		
110-003	CUMMINS SPIN ON FUEL FILTER		

Application Version 12.0.703  
 Data Version PRL-30M.018  
 FTL 106 118-25 CRWCB  
 BEACHWOOD



12/31/2025 9:02 AM

Page 4 of 20

Prepared for:  
 BEACHWOOD CITY OF  
 23355 Mercantile Rd  
 Beachwood, OH 44122  
 Phone: 2162921495

Prepared by:  
 Greg Simonic  
 CLEVELAND FREIGHTLINER, INC.  
 10901 Brookpark Rd  
 Parma, OH 44130  
 Phone: 216-267-4800

Data Code	Description	Weight Front	Weight Rear
118-001	FULL FLOW OIL FILTER		
120-998	NO COOLANT FILTER	-10	
266-100	700 SQUARE INCH ALUMINUM RADIATOR		
103-039	ANTIFREEZE TO -34F, OAT (NITRITE AND SILICATE FREE) EXTENDED LIFE COOLANT		
171-007	GATES BLUE STRIPE COOLANT HOSES OR EQUIVALENT		
172-001	CONSTANT TENSION HOSE CLAMPS FOR COOLANT HOSES		
270-016	RADIATOR DRAIN VALVE		
168-002	LOWER RADIATOR GUARD		
134-001	ALUMINUM FLYWHEEL HOUSING		
132-004	ELECTRIC GRID AIR INTAKE WARMER		
155-057	DELCO 12V 29MT STARTER WITH INTEGRATED MAGNETIC SWITCH		

### Transmission

342-582	ALLISON 3000 RDS AUTOMATIC TRANSMISSION WITH PTO PROVISION	200	60
---------	--	-----	----

### Transmission Equipment

343-339	ALLISON VOCATIONAL PACKAGE 223 - AVAILABLE ON 3000/4000 PRODUCT FAMILIES WITH VOCATIONAL MODELS RDS, HS, MH AND TRV		
84B-012	ALLISON VOCATIONAL RATING FOR ON/OFF HIGHWAY APPLICATIONS AVAILABLE WITH ALL PRODUCT FAMILIES		
84C-023	PRIMARY MODE GEARS, LOWEST GEAR 1, START GEAR 1, HIGHEST GEAR 6, AVAILABLE FOR 3000/4000 PRODUCT FAMILIES ONLY		
84D-023	SECONDARY MODE GEARS, LOWEST GEAR 1, START GEAR 1, HIGHEST GEAR 6, AVAILABLE FOR 3000/4000 PRODUCT FAMILIES ONLY		
84E-000	PRIMARY SHIFT SCHEDULE RECOMMENDED BY DTNA AND ALLISON, THIS DEFINED BY ENGINE AND VOCATIONAL USAGE		
84F-000	SECONDARY SHIFT SCHEDULE RECOMMENDED BY DTNA AND ALLISON, THIS DEFINED BY ENGINE AND VOCATIONAL USAGE		
84G-000	PRIMARY SHIFT SPEED RECOMMENDED BY DTNA AND ALLISON, THIS DEFINED BY ENGINE AND VOCATIONAL USAGE		
84H-000	SECONDARY SHIFT SPEED RECOMMENDED BY DTNA AND ALLISON, THIS DEFINED BY ENGINE AND VOCATIONAL USAGE		
84J-000	ENGINE BRAKE RANGE PRESELECT RECOMMENDED BY DTNA AND ALLISON, THIS DEFINED BY ENGINE AND VOCATIONAL USAGE		



Prepared for:  
 BEACHWOOD CITY OF  
 23355 Mercantile Rd  
 Beachwood, OH 44122  
 Phone: 2162921495

Prepared by:  
 Greg Simonic  
 CLEVELAND FREIGHTLINER, INC.  
 10901 Brookpark Rd  
 Parma, OH 44130  
 Phone: 216-267-4800

Data Code	Description	Weight Front	Weight Rear
84K-000	ENGINE BRAKE RANGE ALTERNATE PRESELECT RECOMMENDED BY DTNA AND ALLISON, THIS DEFINED BY ENGINE AND VOCATIONAL USAGE		
84N-011	NEUTRAL AT STOP ENABLED		
84U-000	DRIVER SWITCH INPUT - DEFAULT - NO SWITCHES		
353-076	QUICKFIT BODY LIGHTING CONNECTOR AT END OF FRAME, WITH BLUNTCUTS		
34C-011	ELECTRONIC TRANSMISSION WIRING TO CUSTOMER INTERFACE CONNECTOR		
362-2JT	CUSTOMER INSTALLED CHELSEA 281 SERIES PTO	50	
363-001	PTO MOUNTING, LH SIDE OF MAIN TRANSMISSION ALLISON		
341-018	MAGNETIC PLUGS, ENGINE DRAIN, TRANSMISSION DRAIN, AXLE(S) FILL AND DRAIN		
345-003	PUSH BUTTON ELECTRONIC SHIFT CONTROL, DASH MOUNTED		
97G-004	TRANSMISSION PROGNOSTICS - ENABLED 2013		
370-015	WATER TO OIL TRANSMISSION COOLER, IN RADIATOR END TANK	15	
346-003	TRANSMISSION OIL CHECK AND FILL WITH ELECTRONIC OIL LEVEL CHECK		
35T-001	ATF-SYNTHETIC AUTOMATIC TRANSMISSION FLUID		

### Front Axle and Equipment

400-1A5	DETROIT DA-F-10.0-3 10,000# FF1 71.5 KPI/3.74 DROP SINGLE FRONT AXLE		
* 402-072	MERITOR 15X7 Q+ CAM FRONT BRAKES		
403-002	NON-ASBESTOS FRONT BRAKE LINING		
419-018	WEBB CAST IRON FRONT BRAKE DRUMS	40	
409-006	FRONT OIL SEALS		
408-001	VENTED FRONT HUB CAPS WITH WINDOW, CENTER AND SIDE PLUGS - OIL		
416-022	STANDARD SPINDLE NUTS FOR ALL AXLES		
405-002	MERITOR AUTOMATIC FRONT SLACK ADJUSTERS		
536-050	TRW THP-60 POWER STEERING		
539-003	POWER STEERING PUMP		
534-015	2 QUART SEE THROUGH POWER STEERING RESERVOIR		
40T-002	CURRENT AVAILABLE SYNTHETIC 75W-90 FRONT AXLE LUBE		

### Front Suspension

Application Version 12.0.703  
 Data Version PRL-30M.018  
 FTL 106 118-25 CRWCB  
 BEACHWOOD



12/31/2025 9:02 AM

Page 6 of 20

Prepared for:  
 BEACHWOOD CITY OF  
 23355 Mercantile Rd  
 Beachwood, OH 44122  
 Phone: 2162921495

Prepared by:  
 Greg Simonic  
 CLEVELAND FREIGHTLINER, INC.  
 10901 Brookpark Rd  
 Parma, OH 44130  
 Phone: 216-267-4800

Data Code	Description	Weight Front	Weight Rear
620-062	10,000# TAPERLEAF FRONT SUSPENSION		
619-005	MAINTENANCE FREE RUBBER BUSHINGS - FRONT SUSPENSION		
410-001	FRONT SHOCK ABSORBERS		

**Rear Axle and Equipment**

420-009	MERITOR RS-21-160 21,000# R-SERIES SINGLE REAR AXLE		180
421-489	4.89 REAR AXLE RATIO		
424-001	IRON REAR AXLE CARRIER WITH STANDARD AXLE HOUSING		
386-046	SPL140HD DANA SPICER MAIN DRIVELINE WITH HALF ROUND YOKES	25	25
452-001	DRIVER CONTROLLED TRACTION DIFFERENTIAL - SINGLE REAR AXLE		
878-018	(1) DRIVER CONTROLLED DIFFERENTIAL LOCK REAR VALVE FOR SINGLE DRIVE AXLE		
87B-015	INDICATOR LIGHT FOR EACH DIFFERENTIAL LOCKOUT SWITCH, ENGAGE <5 MPH, DISENGAGE >25 MPH		
* 423-057	MERITOR 15X8.62 Q+ HIGH CAPACITY CAST SPIDER CAM REAR BRAKES, FABRICATED SHOES		-20
433-002	NON-ASBESTOS REAR BRAKE LINING		
434-005	BRAKE CAMS AND CHAMBERS ON FORWARD SIDE OF DRIVE AXLE(S) WITH AUXILIARY SUPPORT BRACKETS		
451-001	CAST IRON OUTBOARD REAR BRAKE DRUMS		20
440-006	REAR OIL SEALS		
426-1B2	BENDIX EVERSURE LONGSTROKE 1-DRIVE AXLE SPRING PARKING CHAMBERS		
428-002	MERITOR AUTOMATIC REAR SLACK ADJUSTERS		
41T-002	CURRENT AVAILABLE SYNTHETIC 75W-90 REAR AXLE LUBE		

**Rear Suspension**

622-284	AIRLINER 21,000# REAR SUSPENSION		
621-007	AIRLINER HIGH POSITION RIDE HEIGHT		
431-001	STANDARD AXLE SEATS IN AXLE CLAMP GROUP		
888-077	IGNITION CONTROLLED ELECTRIC DUMP SWITCH FOR AIR SUSPENSION WITH STATE RETENTION		
87D-012	REAR AIR SUSPENSION DUMP VALVE AUTOFILL >5 MPH WITH INDICATOR LIGHT		
910-001	SINGLE AIR REAR SUSPENSION LEVELING VALVE		
623-002	TRANSVERSE CONTROL RODS		

Application Version 12.0.703  
 Data Version PRL-30M.018  
 FTL 106 118-25 CRWCB  
 BEACHWOOD



12/31/2025 9:02 AM

Page 7 of 20

Prepared for:  
 BEACHWOOD CITY OF  
 23355 Mercantile Rd  
 Beachwood, OH 44122  
 Phone: 2162921495

Prepared by:  
 Greg Simonic  
 CLEVELAND FREIGHTLINER, INC.  
 10901 Brookpark Rd  
 Parma, OH 44130  
 Phone: 216-267-4800

Data Code	Description	Weight Front	Weight Rear
439-004	REAR SHOCK ABSORBERS - ONE AXLE (AIR RIDE SUSPENSION)		
<b>Pusher / Tag Equipment</b>			
429-998	NO PUSHER/TAG BRAKE DUST SHIELDS		
<b>Brake System</b>			
018-002	AIR BRAKE PACKAGE		
490-121	WABCO 4S/4M ABS WITH TRACTION CONTROL		
871-001	REINFORCED NYLON, FABRIC BRAID AND WIRE BRAID CHASSIS AIR LINES		
46E-001	STANDARD AIR MANAGEMENT UNIT		
904-001	FIBER BRAID PARKING BRAKE HOSE		
412-001	STANDARD BRAKE SYSTEM VALVES		
46D-002	STANDARD AIR SYSTEM PRESSURE PROTECTION SYSTEM		
413-002	STD U.S. FRONT BRAKE VALVE		
432-003	RELAY VALVE WITH 5-8 PSI CRACK PRESSURE, NO REAR PROPORTIONING VALVE		
480-088	WABCO SYSTEM SAVER HP WITH INTEGRAL AIR GOVERNOR AND HEATER		
479-012	AIR DRYER MOUNTED UNDER HOOD		
460-090	STEEL AIR BRAKE RESERVOIRS, NO TRIPLE OR TORPEDO TANKS		
477-004	PULL CABLES ON ALL AIR RESERVOIR(S)		
485-060	QUICK DISCONNECT FITTING WITH TIRE INFLATION KIT AND CAB BLOW OUT KIT WITH AIR HOSE AND NOZZLE INSIDE DRIVER CAB ENTRY DOOR	2	
<b>Trailer Connections</b>			
481-998	NO TRAILER AIR HOSE		
476-998	NO AIR HOSE HANGER		
914-001	AIR CONNECTIONS TO END OF FRAME WITH GLAD HANDS FOR TRUCK AND NO DUST COVERS		
296-010	PRIMARY CONNECTOR/RECEPTACLE WIRED FOR SEPARATE STOP/TURN, ABS CENTER PIN POWERED THROUGH IGNITION		
303-025	SAE J560 7-WAY PRIMARY TRAILER CABLE RECEPTACLE MOUNTED END OF FRAME		
310-998	NO TRAILER ELECTRICAL CABLE		
<b>Wheelbase &amp; Frame</b>			
545-510	5100MM (201 INCH) WHEELBASE		
546-122	8.0MM X 89.0MM X 261MM STEEL FRAME (0.31X3.50X10.28 INCH) 140KSI	180	40
552-037	1775MM (70 INCH) REAR FRAME OVERHANG		

Application Version 12.0.703  
 Data Version PRL-30M.018  
 FTL 106 118-25 CRWCB  
 BEACHWOOD



12/31/2025 9:02 AM

Page 8 of 20

Prepared for:  
 BEACHWOOD CITY OF  
 23355 Mercantile Rd  
 Beachwood, OH 44122  
 Phone: 2162921495

Prepared by:  
 Greg Simonic  
 CLEVELAND FREIGHTLINER, INC.  
 10901 Brookpark Rd  
 Parma, OH 44130  
 Phone: 216-267-4800

Data Code	Description	Weight Front	Weight Rear
55W-006	FRAME OVERHANG RANGE: 61 INCH TO 70 INCH		
AC8-99D	CALC'D BACK OF CAB TO REAR SUSP C/L (CA) : 87.99 in		
AE8-99D	CALCULATED EFFECTIVE BACK OF CAB TO REAR SUSPENSION C/L (CA) : 84.99 in		
AE4-99D	CALC'D FRAME LENGTH - OVERALL : 309.66 in		
FSS-0LH	CALCULATED FRAME SPACE LH SIDE : 101.52 in		
FSS-0RH	CALCULATED FRAME SPACE RH SIDE : 56.37 in		
AM6-99D	CALC'D SPACE AVAILABLE FOR DECKPLATE : 0.0 in		
553-001	SQUARE END OF FRAME		
550-001	FRONT CLOSING CROSSMEMBER		
559-001	STANDARD WEIGHT ENGINE CROSSMEMBER		
561-001	STANDARD CROSSMEMBER BACK OF TRANSMISSION		
562-001	STANDARD MIDSHIP #1 CROSSMEMBER(S)		
572-001	STANDARD REARMOST CROSSMEMBER		
565-001	STANDARD SUSPENSION CROSSMEMBER		

### Chassis Equipment

556-1AR	THREE-PIECE 14 INCH CHROMED STEEL BUMPER WITH COLLAPSIBLE ENDS	30	
558-001	FRONT TOW HOOKS - FRAME MOUNTED	15	
574-001	BUMPER MOUNTING FOR SINGLE LICENSE PLATE		
585-998	NO MUDFLAP BRACKETS		
590-998	NO REAR MUDFLAPS		
586-024	FENDER AND FRONT OF HOOD MOUNTED FRONT MUDFLAPS		
551-007	GRADE 8 THREADED HEX HEADED FRAME FASTENERS		
44Z-005	EXTERIOR HARNESSSES WRAPPED IN ABRASION TAPE, SECONDARY COVERING, & CONNECTOR PROTECTION		
607-001	CLEAR FRAME RAILS FROM BACK OF CAB TO FRONT REAR SUSPENSION BRACKET, BOTH RAILS OUTBOARD		

### Fifth Wheel

578-998	NO FIFTH WHEEL		
---------	----------------	--	--

### Fuel Tanks

204-215	50 GALLON/189 LITER SHORT RECTANGULAR ALUMINUM FUEL TANK - LH	20	
---------	---	----	--



Prepared for:  
 BEACHWOOD CITY OF  
 23355 Mercantile Rd  
 Beachwood, OH 44122  
 Phone: 2162921495

Prepared by:  
 Greg Simonic  
 CLEVELAND FREIGHTLINER, INC.  
 10901 Brookpark Rd  
 Parma, OH 44130  
 Phone: 216-267-4800

	Data Code	Description	Weight Front	Weight Rear
*	203-025	50 GALLON ALUMINUM HYDRAULIC RESERVOIR, RH WITH 1-1/4 INCH NPT TOP AND BOTTOM END FITTINGS		
	218-005	RECTANGULAR FUEL TANK(S)		
	215-005	PLAIN ALUMINUM/PAINTED STEEL FUEL/HYDRAULIC TANK(S) WITH PAINTED BANDS		
	212-007	FUEL TANK(S) FORWARD		
*	20B-003	SINGLE HYDRAULIC TANK FRAME MOUNTED RH SIDE BACK OF CAB		
	664-004	POLISHED STAINLESS STEEL STEP FINISH		
	205-001	FUEL TANK CAP(S)		
	122-1J1	DETROIT FUEL/WATER SEPARATOR WITH WATER IN FUEL SENSOR, HAND PRIMER AND 12 VOLT PREHEATER"	-5	
	216-020	EQUIFLO INBOARD FUEL SYSTEM		
	20E-004	AUXILIARY FUEL SUPPLY AND RETURN PORTS LOCATED ON LH FUEL TANK		
	202-016	HIGH TEMPERATURE REINFORCED NYLON FUEL LINE		
<b>Tires</b>				
	093-1TB	BRIDGESTONE R238 265/70R19.5 14 PLY RADIAL FRONT TIRES	-58	
*	094-1TB	BRIDGESTONE R238 265/70R19.5 14 PLY RADIAL REAR TIRES		-128
<b>Hubs</b>				
	418-060	CONMET PRESET PLUS PREMIUM IRON FRONT HUBS		
	450-060	CONMET PRESET PLUS PREMIUM IRON REAR HUBS		
<b>Wheels</b>				
	502-1E5	ALCOA 77362X 19.5X7.50 10-HUB PILOT 5.23 INSET ALUMINUM DISC FRONT WHEELS	-64	
	505-1E5	ALCOA 77362X 19.5X7.50 10-HUB PILOT ALUMINUM DISC REAR WHEELS		-128
	524-022	POLISHED DISC SIDE FRONT WHEELS WITH DURA-BRIGHT FINISH		
	525-023	POLISHED OUTER (DISHED SIDE) REAR WHEELS WITH OUTER ONLY DURA-BRIGHT FINISH		
	496-011	FRONT WHEEL MOUNTING NUTS		
	497-011	REAR WHEEL MOUNTING NUTS		
<b>Cab Exterior</b>				
	829-079	154 INCH BBC HIGH-ROOF ALUMINUM CONVENTIONAL CREW CAB	430	250
	650-008	AIR CAB MOUNTING		

Application Version 12.0.703  
 Data Version PRL-30M.018  
 FTL 106 118-25 CRWCB  
 BEACHWOOD



12/31/2025 9:02 AM

Page 10 of 20

Prepared for:  
 BEACHWOOD CITY OF  
 23355 Mercantile Rd  
 Beachwood, OH 44122  
 Phone: 2162921495

Prepared by:  
 Greg Simonic  
 CLEVELAND FREIGHTLINER, INC.  
 10901 Brookpark Rd  
 Parma, OH 44130  
 Phone: 216-267-4800

Data Code	Description	Weight Front	Weight Rear
705-012	CAB ROOF REINFORCEMENTS FOR ROOF MOUNTED COMPONENTS		
678-067	SAFETY YELLOW LH AND RH INTERIOR GRAB HANDLES AND LH AND RH EXTERIOR GRAB HANDLES WITH SINGLE RUBBER INSERT		
646-023	HOOD MOUNTED CHROMED PLASTIC GRILLE		
65X-003	CHROME HOOD MOUNTED AIR INTAKE GRILLE		
644-004	FIBERGLASS HOOD		
652-001	FREIGHTLINER NAME PLATES		
690-017	HOOD LINER, ADDED FIREWALL AND FLOOR HEAT INSULATION	5	
727-1AF	SINGLE 14 INCH ROUND HADLEY AIR HORN UNDER LH DECK	4	
726-002	DUAL ELECTRIC HORNS		
575-001	REAR LICENSE PLATE MOUNT END OF FRAME		
312-104	LED LOW BEAM AND HIGH BEAM HEADLIGHTS WITH CHROME BEZEL		
302-047	LED AERODYNAMIC MARKER LIGHTS		
311-001	DAYTIME RUNNING LIGHTS		
294-1AY	INTEGRAL LED STOP/TAIL/BACKUP LIGHTS		
300-015	STANDARD FRONT TURN SIGNAL LAMPS		
744-103	DUAL WEST COAST BRIGHT FINISH HEATED MIRRORS WITH LED LIGHTS AND LH AND RH REMOTE		
797-001	DOOR MOUNTED MIRRORS		
796-001	102 INCH EQUIPMENT WIDTH		
743-204	LH AND RH 8 INCH BRIGHT FINISH CONVEX MIRRORS MOUNTED UNDER PRIMARY MIRRORS		
74A-001	RH DOWN VIEW MIRROR		
729-001	STANDARD SIDE/REAR REFLECTORS		
677-054	RH AFTERTREATMENT SYSTEM CAB ACCESS WITH PLAIN DIAMOND PLATE COVER		
768-043	63X14 INCH TINTED REAR WINDOW		
661-003	TINTED DOOR GLASS LH AND RH WITH TINTED NON-OPERATING WING WINDOWS		
654-011	RH AND LH ELECTRIC POWERED WINDOWS		
663-013	1-PIECE SOLAR GREEN GLASS WINDSHIELD		
659-019	2 GALLON WINDSHIELD WASHER RESERVOIR WITHOUT FLUID LEVEL INDICATOR, FRAME MOUNTED		

**Cab Interior**

055-019	RUGGED TRIM PACKAGE		
707-107	GRAY & CARBON VINYL INTERIOR "RUGGED"		

Application Version 12.0.703  
 Data Version PRL-30M.018  
 FTL 106 118-25 CRWCB  
 BEACHWOOD



12/31/2025 9:02 AM

Page 11 of 20

Prepared for:  
 BEACHWOOD CITY OF  
 23355 Mercantile Rd  
 Beachwood, OH 44122  
 Phone: 2162921495

Prepared by:  
 Greg Simonic  
 CLEVELAND FREIGHTLINER, INC.  
 10901 Brookpark Rd  
 Parma, OH 44130  
 Phone: 216-267-4800

Data Code	Description	Weight Front	Weight Rear
70K-020	CARBON WITH PREMIUM GUNMETAL ACCENT (RUGGED)		
706-013	MOLDED DOOR PANEL		
708-013	MOLDED PLASTIC DOOR PANEL		
772-006	BLACK MATS WITH SINGLE INSULATION		
785-026	(1)DASH MOUNTED 12V POWER OUTLET, (1)DASH MOUNTED DUAL USB-C OUTLET		
691-001	FORWARD ROOF MOUNTED CONSOLE		
693-035	LH AND RH KICKPLATES		
738-021	DIGITAL ALARM CLOCK IN DRIVER DISPLAY		
742-007	(2) CUP HOLDERS LH AND RH DASH		
680-029	M2/SD DASH		
720-002	2-1/2 LB. FIRE EXTINGUISHER	5	
700-002	HEATER, DEFROSTER AND AIR CONDITIONER		
701-008	STANDARD HVAC DUCTING WITH SNOW SHIELD FOR FRESH AIR INTAKE		
703-005	MAIN HVAC CONTROLS WITH RECIRCULATION SWITCH		
170-015	STANDARD HEATER PLUMBING		
130-041	VALEO HEAVY DUTY A/C REFRIGERANT COMPRESSOR		
702-002	BINARY CONTROL, R-134A		
739-034	PREMIUM INSULATION		
285-013	SOLID-STATE CIRCUIT PROTECTION AND FUSES		
280-007	12V NEGATIVE GROUND ELECTRICAL SYSTEM		
324-1B2	PREMIUM LED CAB LIGHTING		
787-998	NO SECURITY DEVICE		
657-001	DOOR LOCKS AND IGNITION SWITCH KEYED THE SAME		
78G-004	KEY QUANTITY OF 4		
655-028	LH AND RH ELECTRIC DOOR LOCKS WITH AUTO UNLOCK FEATURE WHEN DOOR IS SET FROM OPEN TO CLOSED POSITION		
740-998	NO MATTRESS	-20	-15
722-028	TRIANGULAR REFLECTORS KIT WITHOUT FLARES SHIPPED LOOSE IN CAB	10	
756-338	BASIC ISRINGHAUSEN HIGH BACK AIR SUSPENSION DRIVERS SEAT WITH MECHANICAL LUMBAR AND INTEGRATED CUSHION EXTENSION	30	
760-336	BASIC ISRI HIGH BACK NON SUSPENSION PASSENGER SEAT WITH FORE AND AFT ADJUSTMENT		
762-342	SEATS INC FULL WIDTH REAR BENCH SEAT WITH FOLDING BACK	60	20



Prepared for:  
 BEACHWOOD CITY OF  
 23355 Mercantile Rd  
 Beachwood, OH 44122  
 Phone: 2162921495

Prepared by:  
 Greg Simonic  
 CLEVELAND FREIGHTLINER, INC.  
 10901 Brookpark Rd  
 Parma, OH 44130  
 Phone: 216-267-4800

Data Code	Description	Weight Front	Weight Rear
711-004	LH AND RH INTEGRAL DOOR PANEL ARMRESTS		
758-1AK	BLACK VINYL DRIVER SEAT COVER		
761-1AK	BLACK VINYL PASSENGER SEAT COVER		
755-1AK	BLACK VINYL REAR PASSENGER SEAT COVER		
763-102	HIGH VISIBILITY ORANGE SEAT BELTS		
532-002	ADJUSTABLE TILT AND TELESCOPING STEERING COLUMN		
540-044	4-SPOKE 18 INCH (450MM) BLACK STEERING WHEEL WITH SWITCHES		
765-002	DRIVER AND PASSENGER INTERIOR SUN VISORS		

### Instruments & Controls

106-002	ELECTRONIC ACCELERATOR CONTROL		
732-998	NO INSTRUMENT PANEL-DRIVER		
734-022	FULLY CONFIGURABLE CENTER INSTRUMENT PANELS		
87L-001	ENGINE PTO SPEED CONTROL WITH PARK BRAKE INTERLOCK		
870-002	BRIGHT ARGENT FINISH GAUGE BEZELS		
486-001	LOW AIR PRESSURE INDICATOR LIGHT AND AUDIBLE ALARM		
840-001	DUAL NEEDLE PRIMARY AND SECONDARY AIR PRESSURE GAUGE		
198-025	INTAKE MOUNTED AIR RESTRICTION INDICATOR WITHOUT GRADUATIONS		
721-003	87 DECIBELS TO 112 DECIBELS AUTOMATIC SELF-ADJUSTING BACKUP ALARM		3
149-015	ELECTRONIC CRUISE CONTROL WITH CONTROLS ON STEERING WHEEL SPOKES		
156-007	KEY OPERATED IGNITION SWITCH AND INTEGRAL START POSITION; 4 POSITION OFF/RUN/START/ACCESSORY		
157-007	MANUAL REMOTE ENGINE STOP/START WITH PTO RE-ENGAGE		
811-044	PREMIUM INSTRUMENT CLUSTER WITH 5.0 INCH TFT COLOR DISPLAY		
81B-003	DIGITAL PANEL LAMP DIMMER SWITCH IN DRIVER DISPLAY		
160-038	HEAVY DUTY ONBOARD DIAGNOSTICS INTERFACE CONNECTOR LOCATED BELOW LH DASH		
844-001	2 INCH ELECTRIC FUEL GAUGE		
148-072	ENGINE REMOTE INTERFACE WITH ONE OR MORE SET SPEEDS		
48H-004	QUICKFIT POWERTRAIN INTERFACE CONNECTOR UNDER CAB WITH BLUNTCUTS		



Prepared for:  
 BEACHWOOD CITY OF  
 23355 Mercantile Rd  
 Beachwood, OH 44122  
 Phone: 2162921495

Prepared by:  
 Greg Simonic  
 CLEVELAND FREIGHTLINER, INC.  
 10901 Brookpark Rd  
 Parma, OH 44130  
 Phone: 216-267-4800

Data Code	Description	Weight Front	Weight Rear
163-014	ENGINE REMOTE INTERFACE CONNECTOR AT POWERTRAIN INTERFACE CONNECTOR		
856-001	ELECTRICAL ENGINE COOLANT TEMPERATURE GAUGE		
864-001	2 INCH TRANSMISSION OIL TEMPERATURE GAUGE		
867-004	ELECTRONIC OUTSIDE TEMPERATURE SENSOR DISPLAY IN DRIVER MESSAGE CENTER		
830-017	ENGINE AND TRIP HOUR METERS INTEGRAL WITHIN DRIVER DISPLAY		
372-123	PTO CONTROLS FOR ENHANCED VEHICLE ELECTRIC/ELECTRONIC ARCHITECTURE		
736-998	NO OBSTACLE DETECTION SYSTEM		
72J-998	NO DR ASSIST SYSTEM		
73H-014	(1) BACKUP CAMERA-END OF FRAME MOUNTED WITH 15 FOOT EXTRA LONG CABLE COILED AT END OF FRAME		
49B-998	NO VEHICLE STABILITY ADVISOR OR CONTROL		
73B-998	NO LANE DEPARTURE WARNING SYSTEM		
852-002	ELECTRIC ENGINE OIL PRESSURE GAUGE		
679-998	NO OVERHEAD INSTRUMENT PANEL		
746-143	7" B-PANEL INTERACTIVE TOUCHSCREEN DISPLAY RADIO W/ USB-C, APPLE CARPLAY, ANDROID AUTO, BLUETOOTH/AM/FM/SXM/WB, WITH MICROPHONE		
747-001	DASH MOUNTED RADIO		
750-002	(2) RADIO SPEAKERS IN CAB		
753-998	NO AM/FM RADIO ANTENNA		
748-006	POWER AND GROUND WIRING PROVISION OVERHEAD		
749-001	ROOF/OVERHEAD CONSOLE CB RADIO PROVISION		
75W-002	SHARKFIN MULTI-BAND ANTENNA, RIGHT HAND BIAS ROOF MOUNTING LOCATION: AM/FM/WEATHERBAND, WIFI/BLUETOOTH, SDAR/SIRIUSXM, GNSS/GPS		
78C-003	INTEROPERABLE SDAR ANTENNA		
74D-006	STANDARD RADIO WIRING WITH STEERING WHEEL CONTROLS		
810-027	ELECTRONIC MPH SPEEDOMETER WITH SECONDARY KPH SCALE, WITHOUT ODOMETER		
817-001	STANDARD VEHICLE SPEED SENSOR		
812-001	ELECTRONIC 3000 RPM TACHOMETER		
813-1C8	DETROIT CONNECT PLATFORM HARDWARE		

Application Version 12.0.703  
 Data Version PRL-30M.018  
 FTL 106 118-25 CRWCB  
 BEACHWOOD



12/31/2025 9:02 AM

Page 14 of 20

Prepared for:  
 BEACHWOOD CITY OF  
 23355 Mercantile Rd  
 Beachwood, OH 44122  
 Phone: 2162921495

Prepared by:  
 Greg Simonic  
 CLEVELAND FREIGHTLINER, INC.  
 10901 Brookpark Rd  
 Parma, OH 44130  
 Phone: 216-267-4800

Data Code	Description	Weight Front	Weight Rear
8D1-313	3 YEARS DAIMLER CONNECTIVITY BASE PACKAGE ON (FEATURES VARY BY MODEL) POWERED BY DETROIT CONNECT ON CUMMINS ENGINES		
8D4-998	NO FUEL SYSTEMS DATA SERVICE(SCO)		
6TS-005	TMC RP1226 ACCESSORY CONNECTOR LOCATED BEHIND PASSENGER SIDE REMOVEABLE DASH PANEL		
162-002	IGNITION SWITCH CONTROLLED ENGINE STOP		
329-129	FOUR EXTRA HARDWIRED SWITCHES IN DASH, ROUTE TO UNDER CAB, BLUNTCUT		
4C1-025	HARDWIRE SWITCH #1, ON/OFF LATCHING, 20 AMPS IGNITION POWER		
4C2-025	HARDWIRE SWITCH #2, ON/OFF LATCHING, 20 AMPS IGNITION POWER		
4C3-016	HARDWIRE SWITCH #3, ON/OFF LATCHING, 20 AMPS IGNITION POWER		
4C4-016	HARDWIRE SWITCH #4, ON/OFF LATCHING, 20 AMPS IGNITION POWER		
81Y-005	PRE-TRIP INSPECTION FEATURE FOR EXTERIOR LAMPS ONLY		
264-030	(1) OVERHEAD MOUNTED LANYARD CONTROL FOR DRIVER AIR HORN		
482-001	STANDARD TRACTOR PROTECTION VALVE		
883-001	TRAILER HAND CONTROL BRAKE VALVE		
836-015	DIGITAL VOLTAGE DISPLAY INTEGRAL WITH DRIVER DISPLAY		
660-008	SINGLE ELECTRIC WINDSHIELD WIPER MOTOR WITH DELAY		
304-030	ROTARY HEADLAMP SWITCH, MARKER LIGHTS/HEADLIGHTS SWITCH WITH PULL OUT FOR OPTIONAL FOG/ROAD LAMPS		
27D-013	ALTERNATING FLASHING (WIG WAG) HIGH BEAM HEADLAMPS WITH DASH SWITCH AND NO PARK BRAKE INTERLOCK		
882-021	TWO VALVE PARKING BRAKE SYSTEM WITH DASH VALVE CONTROL AUTONEUTRAL AND WARNING INDICATOR		
299-020	SELF CANCELING TURN SIGNAL SWITCH WITH DIMMER, HEADLAMP FLASH, WASH/WIPE/INTERMITTENT		
298-046	INTEGRAL ELECTRONIC TURN SIGNAL FLASHER WITH 40 AMP (20 AMP PER SIDE) TRAILER LAMP CAPACITY		
87T-998	NO WRG/SW-OPTL #2,CHAS,AIR		

**Design**

065-000 PAINT: ONE SOLID COLOR

**Color**

Application Version 12.0.703  
 Data Version PRL-30M.018  
 FTL 106 118-25 CRWCB  
 BEACHWOOD



12/31/2025 9:02 AM

Page 15 of 20

Prepared for:  
 BEACHWOOD CITY OF  
 23355 Mercantile Rd  
 Beachwood, OH 44122  
 Phone: 2162921495

Prepared by:  
 Greg Simonic  
 CLEVELAND FREIGHTLINER, INC.  
 10901 Brookpark Rd  
 Parma, OH 44130  
 Phone: 216-267-4800

Data Code	Description	Weight Front	Weight Rear
980-5F6	CAB COLOR A: L0006EY WHITE ELITE EY		
986-020	BLACK, HIGH SOLIDS POLYURETHANE CHASSIS PAINT		
963-003	STANDARD E COAT/UNDERCOATING		

#### Extended Front Axle Coverage

WA4-047	AXLE: DETROIT FRONT ONLY: MD MODERATE 5 YEARS/100,000 MILES/161,000 KM EXTENDED AXLE COVERAGE
---------	---

#### Certification / Compliance

996-001	U.S. FMVSS CERTIFICATION, EXCEPT SALES CABS AND GLIDER KITS
---------	---

### TOTAL VEHICLE SUMMARY

#### Weight Summary

	Weight Front	Weight Rear	Total Weight
Factory Weight <sup>+</sup>	6749 lbs	3792 lbs	10541 lbs
<b>Total Weight<sup>+</sup></b>	<b>6749 lbs</b>	<b>3792 lbs</b>	<b>10541 lbs</b>

#### Extended Warranty

WAI-45C	CUM 2017 B6.7: HD1 MD DTY 5 YEARS / 100,000 MILES / 161,000 KM EXTENDED WARRANTY. FEX APPLIES
WAX-090	CUM 2017 B6.7: AT3 MD DTY 5 YEARS / 100,000 MILES / 161,000 KM AFTERTREATMENT. FEX APPLIES
WBB-2VP	EXT ULTIMATE TRUCK CHASSIS: US MD STANDARD-MODERATE 5 YEARS/100,000 MILES/161,000 KM
WAL-231	AXLE: NON-DETROIT SINGLE REAR ONLY: MD MODERATE 5 YEARS/100,000 MILES/161,000 KM EXTENDED COVERAGE

(+) Weights shown are estimates only.

If weight is critical, contact Customer Application Engineering.

(\*\*\*) All cost increases for major components (Engines, Transmissions, Axles, Front and Rear Tires) and government mandated requirements, tariffs, and raw material surcharges will be passed through and added to factory invoices.

Application Version 12.0.703  
 Data Version PRL-30M.018  
 FTL 106 118-25 CRWCB  
 BEACHWOOD



12/31/2025 9:02 AM

Page 16 of 20

**Prepared for:**  
BEACHWOOD CITY OF  
23355 Mercantile Rd  
Beachwood, OH 44122  
Phone: 2162921495

**Prepared by:**  
Greg Simonic  
CLEVELAND FREIGHTLINER, INC.  
10901 Brookpark Rd  
Parma, OH 44130  
Phone: 216-267-4800

Application Version 12.0.703  
Data Version PRL-30M.018  
FTL 106 118-25 CRWCB  
BEACHWOOD



12/31/2025 9:02 AM

Page 17 of 20

Prepared for:  
 BEACHWOOD CITY OF  
 23355 Mercantile Rd  
 Beachwood, OH 44122  
 Phone: 2162921495

Prepared by:  
 Greg Simonic  
 CLEVELAND FREIGHTLINER, INC.  
 10901 Brookpark Rd  
 Parma, OH 44130  
 Phone: 216-267-4800

## D I M E N S I O N S

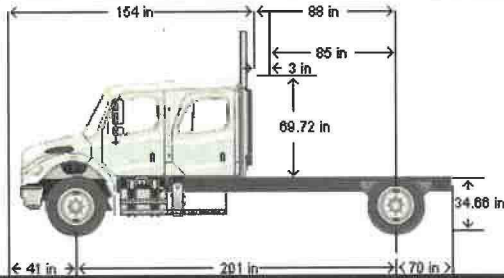

### VEHICLE SPECIFICATIONS SUMMARY - DIMENSIONS

Model .....	M2106
Wheelbase (545) .....	5100MM (201 INCH) WHEELBASE
Rear Frame Overhang (552) .....	1775MM (70 INCH) REAR FRAME OVERHANG
Fifth Wheel (578) .....	NO FIFTH WHEEL
Mounting Location (577) .....	NO FIFTH WHEEL LOCATION
Maximum Forward Position (in) .....	0
Maximum Rearward Position (in) .....	0
Amount of Slide Travel (in) .....	0
Slide Increment (in) .....	0
Desired Slide Position (in) .....	0.0
Cab Size (829) .....	154 INCH BBC HIGH-ROOF ALUMINUM CONVENTIONAL CREW CAB
Sleeper (682) .....	NO SLEEPER BOX/SLEEPER/CAB
Exhaust System (016) .....	RH OUTBOARD UNDER STEP MOUNTED HORIZONTAL AFTERTREATMENT SYSTEM ASSEMBLY WITH RH C-PILLAR MOUNTED VERTICAL TAILPIPE
Cab to Body Clearance (in) .....	3.0

### TABLE SUMMARY - DIMENSIONS



Prepared for:  
 BEACHWOOD CITY OF  
 23355 Mercantile Rd  
 Beachwood, OH 44122  
 Phone: 2162921495

Prepared by:  
 Greg Simonic  
 CLEVELAND FREIGHTLINER, INC.  
 10901 Brookpark Rd  
 Parma, OH 44130  
 Phone: 216-267-4800

Dimensions	Inches
Bumper to Back of Cab (BBC)	153.5
Bumper to Centerline of Front Axle (BA)	40.7
Front Axle to Back of Cab (AC)	112.8
Min. Cab to Body Clearance (CB)	3.0
Back of Cab to Centerline of Rear Axle(s) (CA)	88.0
Effective Back of Cab to Centerline of Rear Axle(s) (Effective CA)	85.0
Back of Cab Protrusions (Exhaust/Intake) (CP)	2.0
Back of Cab Protrusions (Side Extenders/Trim Tab) (CP)	0.0
Back of Cab Protrusions (CNG Tank)	0.0
Back of Cab Clearance (CL)	3.0
Back of Cab to End of Frame	157.9
Cab Height (CH)	69.7
Wheelbase (WB)	200.8
Frame Overhang (OH)	69.9
Overall Frame Length	309.7
Overall Length (OAL)	311.4
Rear Axle Spacing	0.0
Unladen Frame Height at Centerline of Rear Axle	34.7

Performance calculations are estimates only. If performance calculations are critical, please contact Customer Application Engineering.



Prepared for:  
 BEACHWOOD CITY OF  
 23355 Mercantile Rd  
 Beachwood, OH 44122  
 Phone: 2162921495

Prepared by:  
 Greg Simonic  
 CLEVELAND FREIGHTLINER, INC.  
 10901 Brookpark Rd  
 Parma, OH 44130  
 Phone: 216-267-4800

## Q U O T A T I O N

### M2 106 PLUS CONVENTIONAL CHASSIS

SET BACK AXLE - TRUCK CUM B6.7 325 HP @ 2400 RPM, 2600 GOV, 750 LB-FT @ 1800 RPM ALLISON 3000 RDS AUTOMATIC TRANSMISSION WITH PTO PROVISION MERITOR RS-21-160 21,000# R-SERIES SINGLE REAR AXLE AIRLINER 21,000# REAR SUSPENSION DETROIT DA-F-10.0-3 10,000# FF1 71.5 KPI/3.74 DROP SINGLE FRONT AXLE	10,000# TAPERLEAF FRONT SUSPENSION 154 INCH BBC HIGH-ROOF ALUMINUM CONVENTIONAL CREW CAB 5100MM (201 INCH) WHEELBASE NO FIFTH WHEEL 8.0MM X 89.0MM X 261MM STEEL FRAME (0.31X3.50X10.28 INCH) 140KSI 1775MM (70 INCH) REAR FRAME OVERHANG
--	--

		PER UNIT		TOTAL
VEHICLE PRICE	TOTAL # OF UNITS (1)	\$	112,945	\$ 112,945
EXTENDED WARRANTY		\$	3,795	\$ 3,795
DEALER INSTALLED OPTIONS		\$	0	\$ 0
<b>CUSTOMER PRICE BEFORE TAX</b>		<b>\$</b>	<b>116,740</b>	<b>\$ 116,740</b>

### TAXES AND FEES

TAXES AND FEES	\$	0	\$	0
OTHER CHARGES	\$	0	\$	0

### TRADE-IN

<b>TRADE-IN ALLOWANCE</b>	<b>\$</b>	<b>(0)</b>	<b>\$</b>	<b>(0)</b>
---------------------------	-----------	------------	-----------	------------

<b>BALANCE DUE</b>	<b>(LOCAL CURRENCY)</b>	<b>\$</b>	<b>116,740</b>	<b>\$</b>	<b>116,740</b>
--------------------	-------------------------	-----------	----------------	-----------	----------------

The proposed vehicle/vehicles may be available with safety and collision mitigation options outlined in the specifications if included. If this is a chassis order, please consult with your bodybuilder to ensure the specification includes all dimensions, ratings, and necessary components for body installation. All specifications and pricing are subject to final production, engineering review, availability, and Mfg. surcharges and tariffs. The purchasing entity is responsible for determining eligibility and requesting permission for cooperative purchase programs. Invoicing will occur upon delivery to the customer or dropship point and will be payable upon receipt. Payment is due on receipt of the invoice. Titles will be transferred and delivered promptly upon receipt of payment. Reconfirm pricing after 30 days. A purchase order or signed proposal agrees to the pricing, specifications, and terms, and the cooperative contract rules if applicable unless other arrangements are agreed upon but does not guarantee production. Vehicle/Chassis is proposed under State Contract # DOT11825-5 cooperative pricing. Pricing is valid for Ohio municipal purchases and eligibility coincides with contract terms and dates. Contracts can be found at the link below.

[https://ohiobuys.ohio.gov/page.aspx/en/ctr/contract\\_manage\\_public/31306](https://ohiobuys.ohio.gov/page.aspx/en/ctr/contract_manage_public/31306)

#### APPROVAL:

Please indicate your acceptance of this quotation by signing below:

Customer: X \_\_\_\_\_ Date: \_\_\_ / \_\_\_ / \_\_\_.





**Z5 Oakwood Village**  
**1 Acorn Drive**  
**Oakwood Village OH 44146-5550**

**QUOTE**

**Quote ID:** Z5-Q10559 - 3  
**Quote Date:** 2/2/2026  
**Quote Valid Until:** 3/4/2026  
**Salesperson:** Chris Workman  
**Entered by:** Chris Workman  
 Page 1 of 2

**Bill To Customer:**

City of Beachwood  
 2700 Richmond Road  
 Po Box 22659  
 Beachwood OH 44122

**Sold To Customer:**

City of Beachwood  
 2700 Richmond Road  
 Po Box 22659  
 Beachwood OH 44122

**Ship-To:**

City of Beachwood  
 2700 Richmond Road  
 Po Box 22659  
 Beachwood OH 44122

**Contact:**

**Phone:** 1 (216) 292-1928

**Email:**

<b>Make:</b>	Freightliner	<b>Model:</b>	M2 106	<b>Year:</b>	2027	<b>Single/Dual:</b>	DRW	<b>Engine Type:</b>	Diesel
<b>Cab Type:</b>	Crew Cab	<b>Wheelbase:</b>	201	<b>Cab-to-Axle:</b>	85	<b>Roof:</b>		<b>Drive Type:</b>	4x2

**Description**

Furnish and install:

Knapheide KUVcc series service body, model KC132H2094, with the following:

- \* 133.25" long x 94" wide x 90" high (72.5" interior clear height)
- \* 20" compartment depth with 54" wide cargo area
- \* Solid rear doors (49.5" clear door width x 63.1" clear door height)
- \* Automotive style rotary latches
- \* Stainless steel continuous hinges and pins
- \* Double spring over center vertical door retainers
- \* Standard shelving package
- \* 9" x 30" window in bulkhead
- \* Two [2] rear access doors on upper roof structure
- \* Grab handle - right rear in cargo area
- \* Entire body has e-coat primer
- \* LED surface mount light kit
- \* Two [2] interior dome lights with switch inside curbside rear door
- \* Body factory undercoated
- \* Body painted white
- \* Hitch not included

NOTE: Truck reprogramming may be required by the dealer for the S/T/T lights.

This is not included in Zoresco's price and is the responsibility of the dealer. Zoresco can provide this service for an additional cost (prices vary depending upon local dealer's labor rates and transportation costs).

Class V 2.5" receiver hitch

- \* Hitch rated at 21,000 M.G.T.W.
- \* 2.5" receiver tube
- \* 2" reducer sleeve

Note: Do not exceed the towing capacity specified by the manufacturer if it is less than the above stated hitch capacity.

Ultimate power square design inverter, model : UP12/4000SD-CG

- \* 4000 watt
- \* Pure sine wave
- \* Includes auxiliary battery
- \* Installed in right front compartment

7-way round trailer plug

Buyers flexible rubber step with galvanized steel step

- \* 12" wide step x 13" high
- \* Installed on rear bumper curb side
- \* Stainless grab handle installed on passenger side rear of body

LED strobe lights in rear S/T/T lights

- \* Wired to the OEM upfitter switch



**Z5 Oakwood Village**  
**1 Acorn Drive**  
**Oakwood Village OH 44146-5550**

**QUOTE**

Quote ID: Z5-Q10559 - 3  
 Quote Date: 2/2/2026  
 Quote Valid Until: 3/4/2026  
 Salesperson: Chris Workman  
 Entered by: Chris Workman  
 Page 2 of 2

Description
Ecco 4-corner amber/green strobe system, model ED3511AG: * [2] strobes installed on upper rear of body - One each side * [2] strobes installed on front grille of truck - One each side as wide as possible * Strobe lights wired through factory OEM upfitter switch ECCO Class I LED safety director light bar, Model: ED6047A * 47" length * Amber lights * Left, right and center-out patterns * Soft touch controller * 35 flash patterns * Designed for work trucks, tow trucks, utility vehicles and municipal fleets * Extruded aluminum housing with polycarbonate lens

<b>Sub Total:</b>	<b>\$40,228.00</b>
<b>Sales Tax:</b>	<b>\$0.00</b>
<b>Grand Total:</b>	<b>\$40,228.00</b>

**Payment Terms:** NET 10  
**Delivery Terms:** Customer

**Notes:**

Price quoted is FOB Zoresco Equipment - Oakwood Village, OH

**NOTE:**

- \* Quote is based on chassis spec with 19.5" diameter wheels. If wheel size increases a new quote will need to be provided.
- \* Inverter on quote to be verified by customer for compatibility for intended usage
- \* Final chassis specs to be provided to ensure fitment prior to processing order due to custom ordered body
- \* Outside of chassis frame rails must be clear of components for body mounting (air, fuel, DEF tanks, etc.)

Individual priced items are based on all items being equipped on unit at this time. Items not purchased now, but added at a later date may not be at the price indicated in this quote due to manufacturing and/or installation processes. Please review the above information completely. These specifications as shown constitute an order and any changes must be made in writing. If there are no questions, please sign and return. We must be in receipt of a signed copy prior to processing your order.

Accepted by:	
Date:	
P.O. Number:	

\* Terms are Due Upon Receipt unless prior credit arrangements are made at the time of order.

Zoresco shall not be liable for failure to perform or for any delay in performance due to any Acts of God, strike or other labor difficulty, Act of any Governmental Authority or of the purchaser, fuel shortage, wrecks or delays in transportation, inability to obtain necessary labor, material or manufacturing facilities from usual sources or failure of suppliers to meet their contractual obligations or due to any cause beyond its reasonable control. If any such events occur, Zoresco may extend delivery dates by a period of time necessary to overcome the effects of such delay, allocate available products or cancel purchase orders. Due to fluctuations in material costs and availability, quotes published by Zoresco will be honored for no more than 30 days from the date of issue.